



CUSHMAN™

OWNER'S GUIDE
REFRESHER FS4



636638

ISSUED MARCH 2014

REVISED NOVEMBER 2015

WELCOME

Thank you for purchasing this vehicle. Before driving the vehicle, we ask you to spend some time reading this Owner's Guide. This guide contains the information that will assist you in maintaining this highly reliable vehicle. Some illustrations may show items that are optional for your vehicle. This guide covers the operation of several vehicles; therefore, some illustrations may not represent your vehicle. Physical differences in controls will be illustrated.

Most of the service procedures in this guide can be accomplished using common, automotive hand tools. Contact your service representative on servicing the vehicle in accordance with the Periodic Service Schedule.

Repair or replacement parts are available through your E-Z-GO retailer or Genuine E-Z-GO Service Parts Department.

The following information is needed when contacting E-Z-GO concerning service or parts for your vehicle:

Vehicle Model: _____

VIN or Serial Number: _____

OWNER'S GUIDE GASOLINE POWERED VEHICLE

REFRESHER FS4

STARTING MODEL YEAR 2014

CALIFORNIA Proposition 65 Warning

WARNING: Engine exhaust, some of its constituents, and certain vehicle components contain or emit chemicals known to the State of California to cause cancer and birth defects or other reproductive harm. In addition, certain fluids contained in vehicles and certain products of component wear contain or emit chemicals known to the State of California to cause cancer and birth defects or other reproductive harm.

Never modify the vehicle in any way that will alter the weight distribution of the vehicle, decrease its stability or increase the speed beyond the factory specifications. Such modifications can cause serious personal injury or death. E-Z-GO Division of Textron Inc. prohibits and disclaims responsibility for any such modifications or any other alteration which would adversely affect the safety of the vehicle.

E-Z-GO Division of Textron Inc. reserves the right to incorporate engineering and design changes to products in this manual, without obligation to include these changes on units sold previously.

The information contained in this manual may be revised periodically by E-Z-GO, and therefore is subject to change without notice.

E-Z-GO DISCLAIMS LIABILITY FOR ERRORS IN THIS MANUAL, and SPECIFICALLY DISCLAIMS LIABILITY FOR INCIDENTAL AND CONSEQUENTIAL DAMAGES resulting from the use of the information and materials in this Manual.

These are the original instructions as defined by 2006/42/EC.

CONTACT US:

**E-Z-GO Division of Textron Inc.
1451 Marvin Griffin Road.
Augusta, Georgia, USA 30906-3852**

North America:

Technical Assistance & Warranty PHONE: 1-800-774-3946 FAX: 1-800-448-8124

Service Parts PHONE: 1-888-GET-EZGO (1-888-438-3946) FAX: 1-800-752-6175

International:

PHONE: 001-706-798-4311 FAX: 001-706-771-4609

FORWARD

This vehicle has been designed and manufactured in the United States of America (USA). The Standards and Specifications listed in the following text originate in the USA unless otherwise indicated.

The use of non-Original Equipment Manufacturer (OEM) approved parts may void the warranty.

Overfilling battery may void the warranty.

Tampering with or adjusting the governor to permit vehicle to operate at above factory specifications will void the vehicle warranty.

When servicing engines, all adjustments and replacement components must be per original vehicle specifications in order to maintain the United States of America Federal and State emission certification applicable at the time of manufacture.

BATTERY PROLONGED STORAGE

Batteries self-discharge over time. The rate of self-discharge varies depending on the ambient temperature, the age and condition of the batteries.

Fully charged batteries will not freeze in winter temperatures unless the temperature falls below -75°F (-60°C).

BATTERY DISPOSAL

Lead-acid batteries are recyclable. Return whole scrap batteries to distributor, manufacturer or lead smelter for recycling. For neutralized spills, place residue in acid-resistant containers with absorbent material, sand or earth and dispose of in accordance with local, state and federal regulations for acid and lead compounds. Contact local and/or state environmental officials regarding disposal information.

SAFETY

GENERAL	1
NOTICES, CAUTIONS, WARNINGS, AND DANGERS	1
GENERAL OPERATION	3
MAINTENANCE	4
LABELS AND PICTOGRAMS	5

GENERAL SPECIFICATIONS

.....	10
VEHICLE DIMENSIONS	11
TURNING DIAMETER AND INCLINE INFORMATION	12

INTRODUCTION

REFRESHER FS4 VEHICLE OVERVIEW	15
VEHICLE FEATURES	15
General Information	15
Key / Light Switch	16
Fuel Gauge with Low Oil Pressure Indicator	16
12V Outlet	16
Direction Selector	16
Accelerator Pedal	16
Brake and Park Brake	16
Horn	16
Rear View Mirror	16
Cup Holder	16
Choke	16
Steering Wheel	16
Seat	16
Hip Restraint	16
Glove Box	16

OPERATING PROCEDURES

SERIAL NUMBER LOCATION	19
BEFORE INITIAL USE	20
OPERATING THE VEHICLE	20
Run-In	21
Cold Starting	21

TABLE OF CONTENTS

STARTING AND DRIVING	22
Starting the Vehicle on a Hill	22
Coasting	22
Fuel	23
Fuel Tank	23
Early Production Fuel Tank	23
Late Production Fuel Tank	24
Battery	24
12 Volt Power Outlet	24
Canopy and Windshield	24
REFRESHER VEHICLE OVERVIEW	25
Serial Number Location	25
Emissions Labels and Engine Access	25
REFRESHMENT UNIT OPERATION	26
Lockdown Mechanism	26
Module Removal and Installation	26
Slide Out Compartments	29
Removable Shelves and Inserts	30
Compartment Storage	32
Drawer Operation	34
Trash Compartment Operation	35
Keys and Locks	35
Cleaning the Refresher Unit	35
CHANGING THE CANOPY	36
MAINTENANCE	
VEHICLE CLEANING AND CARE.....	39
Vehicle Cleaning	39
Refresher Unit Cleaning	39
COMMON SENSE OPERATION.....	40
ENVIRONMENTAL CONCERNS	40
REPAIR.....	40
Lifting the Vehicle	41
WHEELS AND TIRES.....	41
Tire Repair	42
Wheel Installation	43

LIGHT BULB REPLACEMENT	43
FUSE REPLACEMENT	43
VEHICLE WITH A DISCHARGED BATTERY	44
TRANSPORTING VEHICLE	44
Neutral Lock	44
SERVICE AND MAINTENANCE	45
ROUTINE MAINTENANCE	46
Tire Inspection	46
Rear Axle	46
FOUR CYCLE ENGINE	46
Engine Specifications	46
Engine Description	47
Checking the Oil Level	47
Changing the Oil	47
STARTER/GENERATOR BELT TENSION	50
Adjusting the Belt	50
BATTERY CLEANING	50
AIR INTAKE AND COOLING FINS	51
REAR AXLE	52
Checking the Lubricant Level	52
AIR CLEANER INSPECTION AND REPLACEMENT	52
Cleaning the Air Filter Element	52
SPARK PLUG	53
BRAKES	53
Periodic Brake Test	54
LUBRICATION	55
PROLONGED STORAGE	55
CAPACITIES AND REPLACEMENT PARTS	56
HARDWARE	57
PERIODIC SERVICE SCHEDULE	
PERIODIC SERVICE SCHEDULE	59
APPENDIX A	
DECLARATION OF CONFORMITY	A

Notes:

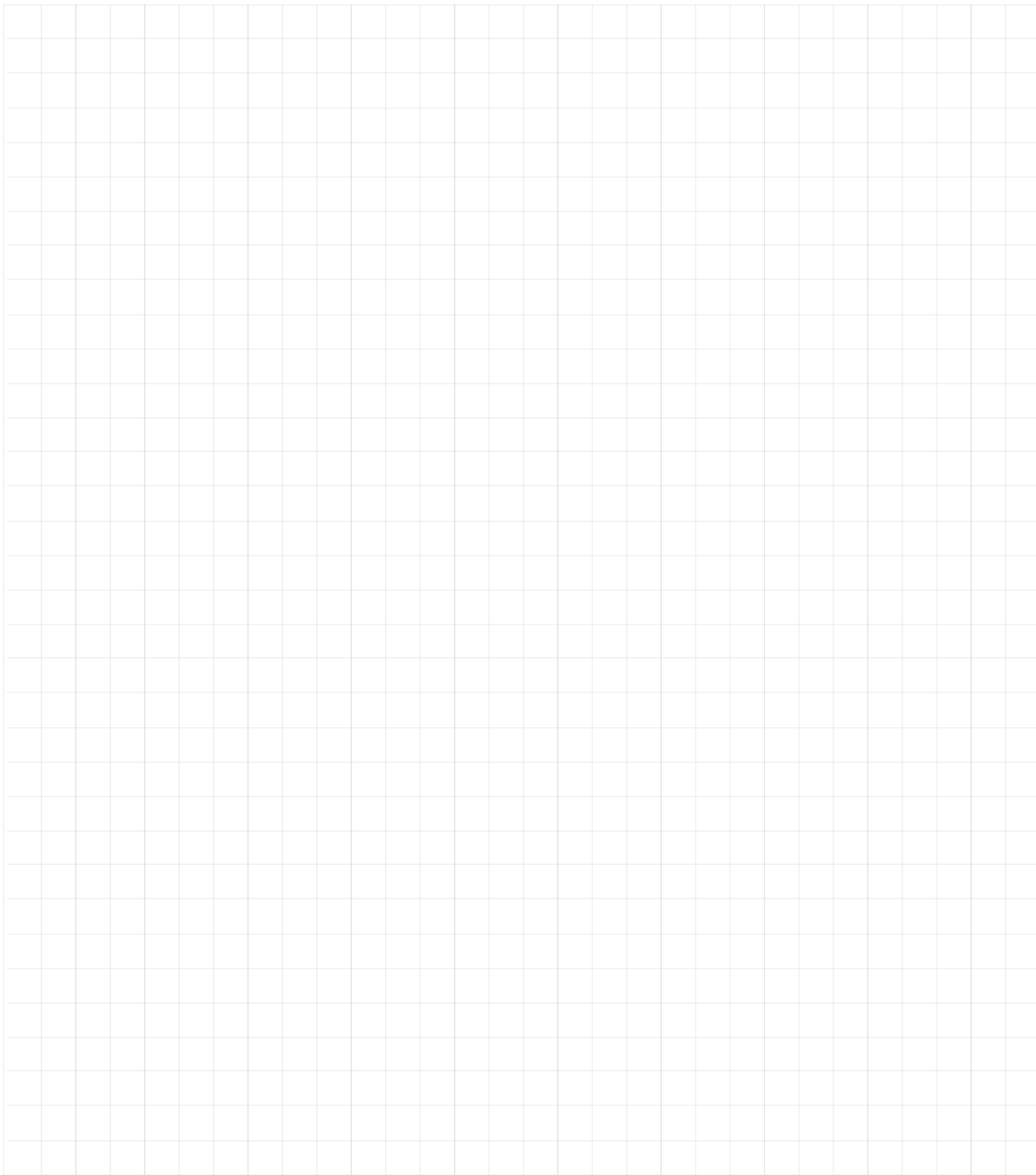

A large grid of graph paper for taking notes, consisting of 20 columns and 30 rows of small squares.

Read all of SAFETY and this section before attempting any procedure. Pay particular attention to Notices, Cautions, Warnings and Dangers.

SAFETY

GENERAL

For any questions on material contained in this manual, contact an authorized representative for clarification.

Read all labels located on the vehicle. Always replace any damaged or missing labels.

On steep hills it is possible for vehicles to coast at fast speeds. To prevent loss of vehicle control and possible serious injury, speeds should be limited to no more than the maximum attainable speed on level ground. See GENERAL SPECIFICATIONS. Limit speed by applying the service brake. Catastrophic damage to the drivetrain components due to excessive speed may result from driving the vehicle above specified speed. Damage caused by excessive speed may cause a loss of vehicle control, is costly, is considered abuse and will not be covered under warranty.

If the vehicle is to be used in a commercial environment, signs similar to the ones illustrated should be used to warn of situations that could result in an unsafe condition.

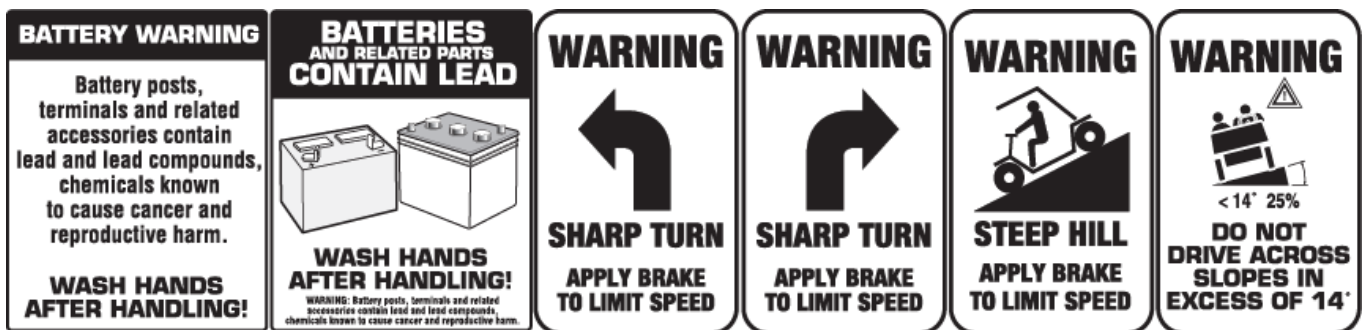

NOTICES, CAUTIONS, WARNINGS, AND DANGERS

Throughout this guide **NOTICE**, **CAUTION**, **WARNING**, and **DANGER** will be used. Please observe these and be aware that servicing a vehicle requires mechanical skill and a regard for conditions that could be hazardous. Improper service or repair may damage the vehicle or render it unsafe.

NOTICE

Addresses practices not related to personal injury.



CAUTION

Indicates a hazardous situation which, if not avoided, could result in minor or moderate injury.



WARNING

Indicates a hazardous situation which, if not avoided, could result in death or serious injury.



DANGER

Indicates a hazardous situation which, if not avoided, will result in death or serious injury.

SAFETY

Read all of SAFETY and this section before attempting any procedure. Pay particular attention to Notices, Cautions, Warnings and Dangers.

This manual has been designed to assist in maintaining the vehicle in accordance with procedures developed by the manufacturer. Adherence to these procedures and troubleshooting tips will ensure the best possible service from the product. To reduce the chance of personal injury or property damage, the following must be carefully observed:

CAUTION

Certain replacement parts can be used independently and/or in combination with other accessories to modify an E-Z-GO-manufactured vehicle to permit the vehicle to operate at or in excess of 20 mph. When an E-Z-GO-manufactured vehicle is modified in any way by the Distributor, Dealer or customer to operate at or in excess of 20mph, UNDER FEDERAL LAW the modified product will be a Low Speed Vehicle (LSV) subject to the strictures and requirements of Federal Motor Vehicle Safety Standard 571.500. In these instances, pursuant to Federal law the Distributor or Dealer MUST equip the product with headlights, rear lights, turn signals, seat belts, top, horn and all other modifications for LSV's mandated in FMVSS 571.500, and affix a Vehicle Identification Number to the product in accordance with the requirements of FMVSS 571.565. Pursuant to FMVSS 571.500, and in accordance with the State laws applicable in the places of sale and use of the product, the Distributor, Dealer or customer modifying the vehicle also will be the Final Vehicle Manufacturer for the LSV, and required to title or register the vehicle as mandated by State law.

E-Z-GO will NOT approve Distributor, Dealer or customer modifications converting E-Z-GO products into LSV's.

The Company recommends that all E-Z-GO products sold as personal transportation vehicles BE OPERATED ONLY BY PERSONS WITH VALID DRIVERS LICENSES, AND IN ACCORDANCE WITH APPLICABLE STATE REQUIREMENTS. This restriction is important to the SAFE USE AND OPERATION of the product.

All customers should adhere to this SAFETY RESTRICTION, in connection with the use of all E-Z-GO products, new and used, the Distributor or Dealer has reason to believe may be operated in personal transportation applications.

Information on FMVSS 571.500 can be obtained at Title 49 of the Code of Federal Regulations, section 571.500, or through the Internet at the web site for the U.S. Department of Transportation - at Dockets and Regulation, then to Title 49 of the Code of Federal Regulations (Transportation).

All vehicles can be used for a variety of tasks beyond the original intended use of the vehicle; therefore, it is impossible to anticipate and warn against every possible combination of circumstances that may occur. No warning can replace good common sense and prudent driving practices.

Good common sense and prudent driving practices do more to prevent accidents and injury than all of the warnings and instructions combined. E-Z-GO strongly suggests that all users and maintenance personnel read this entire manual paying particular attention to the CAUTIONS, WARNINGS and DANGERS contained therein.

If you have any questions regarding this vehicle, contact your E-Z-GO/CUSHMAN dealer or write to the address on the back cover of this publication, Attention: Customer Care Department.

E-Z-GO reserves the right to make design changes without obligation to make these changes on units previously sold. The information contained in this manual is subject to change without notice.

E-Z-GO IS NOT LIABLE FOR ERRORS IN THIS MANUAL. E-Z-GO IS NOT LIABLE FOR INCIDENTAL OR CONSEQUENTIAL DAMAGES THAT RESULT FROM THE USE OF THE MATERIAL IN THIS MANUAL.

This vehicle conforms to the current applicable standard(s) for safety and performance requirements.

These vehicles are designed and manufactured for off-road use. They DO NOT conform to Federal Motor Vehicle Safety Standards of the United States of America (USA) and are not equipped for operation on public streets. Some communities may permit these vehicles to be operated on their streets on a limited basis and in accordance with local ordinances.

Refer to GENERAL SPECIFICATIONS for vehicle seating capacity.

WARNING

Never modify the vehicle in any way that will alter the weight distribution of the vehicle, decrease its stability, extend the stopping distance, or increase the speed beyond the factory specification. Such modifications can result in serious personal injury or death.

Read all of SAFETY and this section before attempting any procedure. Pay particular attention to Notices, Cautions, Warnings and Dangers.

Never modify the vehicle in any way that will alter the weight distribution of the vehicle, decrease its stability, extend the stopping distance, or increase the speed beyond the factory specification. E-Z-GO prohibits and disclaims responsibility for all such modifications which would adversely affect the safety of the vehicle.

Vehicles capable of higher speeds must be limited to no more than speed of other vehicles when used in a golf course environment. Additionally, speed should be further moderated by the environmental conditions, terrain and common sense.

Operation of the vehicle is limited to persons above the height of 59 inches (150 cm).

GENERAL OPERATION

Read the following warnings before attempting to operate the vehicle.

WARNING

To prevent personal injury or death, observe the following:

When vehicle is to be left unattended, turn key to OFF position and remove from switch.

Drive vehicle only as fast as terrain and safety considerations allow. Consider the terrain and traffic conditions. Consider environmental factors which effect terrain and operators ability to control vehicle.

Avoid driving fast downhill. Sudden stops or change of direction may result in a loss of control. Use brake to control speed when traveling down an incline.

Use extra care and reduced speed when driving in poor conditions or on poor surfaces.

Stay in designated areas where provided and avoid steep slopes.

Keep feet, legs, hands, and arms inside vehicle at all times.

Avoid extremely rough terrain.

Check area behind the vehicle before operating in reverse.

Make sure the direction selector is in correct position before pressing accelerator pedal.

Slow down before and during turns.

Always bring vehicle to a complete stop before shifting the direction selector.

See GENERAL SPECIFICATIONS for vehicle load and seating capacity.

NOTICE

Read the following text and warnings before attempting to service vehicle.

In any product, components may eventually fail to perform properly as the result of normal use, age, wear, or abuse.

It is impossible to anticipate all possible component failures or the manner in which each component may fail.

A vehicle requiring repair is no longer functioning as designed, and therefore potentially hazardous. Use extreme care when working on a vehicle. When diagnosing, removing, or replacing components that are not operating correctly, consider the safety of yourself and others in area.

Some components are heavy, spring-loaded, highly corrosive, explosive, may produce high amperage, or reach high temperatures. Exposure to battery acid and hydrogen gas could result in serious bodily injury. Ensure protection of hands, face, feet, and body from injury.

Always use the appropriate tools listed in the tool list and wear the recommended approved safety equipment.

SAFETY

Read all of SAFETY and this section before attempting any procedure. Pay particular attention to Notices, Cautions, Warnings and Dangers.

WARNING

Before working on the vehicle, remove all jewelry.

Be sure no loose clothing or hair can contact moving parts.

Use care not to touch hot objects.

Wear eye protection when working on or around the vehicle. In particular, use care when working around batteries, using solvents or compressed air.

ALWAYS:

- Use the vehicle in a responsible manner and maintain the vehicle in safe operating condition.
- Read and observe all warnings and operation instruction labels affixed to the vehicle.
- Follow all safety rules established in the area where the vehicle is being operated.
- Leave the vehicle and seek shelter when there is a risk of lightning.
- Reduce speed to compensate for poor terrain or conditions.
- Apply service brake to control speed on steep grades.
- Maintain adequate distance between vehicles.
- Reduce speed in wet areas.
- Use extreme caution when approaching sharp or blind turns.
- Use extreme caution when driving over loose terrain.
- Use extreme caution in areas where pedestrians are present.

MAINTENANCE

ALWAYS:

- Replace damaged or missing warning, caution or information labels.
- Maintain the vehicle in accordance with the manufacturer's periodic service schedule.
- Ensure that repairs are performed by trained and qualified personnel.
- Follow the manufacturer's maintenance procedures.
- Insulate any tools used within the battery area in order to prevent sparks or battery explosion.
- Use specified replacement parts, NEVER use replacement parts of lesser quality.
- Use recommended tools.
- Determine that tools and procedures not specifically recommended by the manufacturer will not compromise the safety of personnel nor jeopardize the safe operation of the vehicle.
- Support the vehicle using wheel chocks and jack stands. NEVER get under a vehicle that is supported by a jack. Lift the vehicle in accordance with the manufacturer's instructions.
- Maintain the vehicle in an area away from exposed flame or persons who are smoking.
- Be aware that a vehicle that is not performing as designed is a potential hazard and must not be operated.
- Test drive the vehicle after any repairs or maintenance in a safe area that is free of both vehicular and pedestrian traffic.
- Keep complete records of the maintenance history of the vehicle.

Read all of SAFETY and this section before attempting any procedure. Pay particular attention to Notices, Cautions, Warnings and Dangers.

LABELS AND PICTOGRAMS



614121



601781

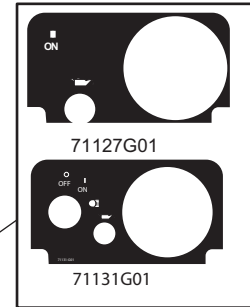

71127G01

71131G01

AUTHORIZED REPRESENTATIVE IN EC IS:

RANSOMES JACOBSEN LTD.
WEST ROAD, IPSWICH,
SUFFOLK, IP3 9TT, UK

614068



608822



27653G01



608527
Engine Compartment



71489G01









74093G01
Near Fuel Tank



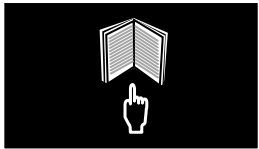

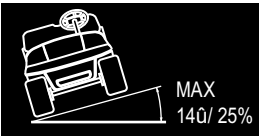
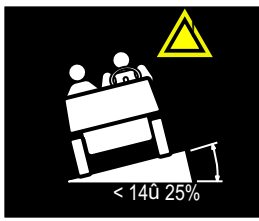

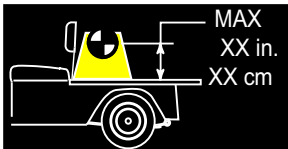
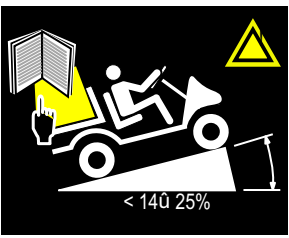
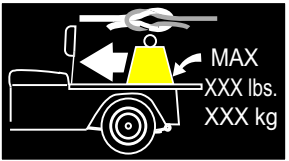
28203G01
On Battery Under Seat

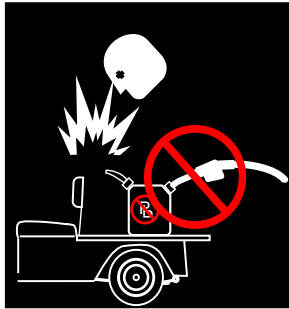
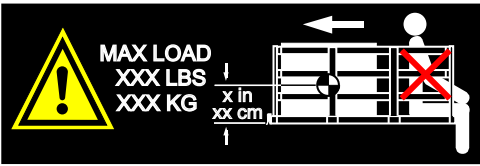
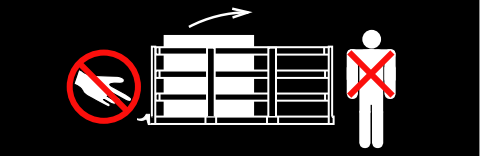
SAFETY

Read all of SAFETY and this section before attempting any procedure. Pay particular attention to Notices, Cautions, Warnings and Dangers.

1.  WARNING
2.  READ MANUAL
3.  WARNING
USE CAUTION IN INCLEMENT WEATHER
4.  WARNING
DO NOT OPERATE UNDER THE INFLUENCE OF DRUGS OR ALCOHOL
5.  MAXIMUM CROSS HILL/RAMP ANGLE AS SPECIFIED
6.  WARNING
MAXIMUM CROSS HILL/RAMP ANGLE AS SPECIFIED
7.  LOAD WITH HIGH CENTER OF GRAVITY COULD RESULT IN TIP OVER
8.  LOAD CENTER OF GRAVITY, MAXIMUM HEIGHT
9.  WARNING
READ MANUAL FOR MAXIMUM LOAD BED CAPACITY.
MAXIMUM RAMP/HILL
10.  SECURE LOAD AS FAR FORWARD AS POSSIBLE.
MAXIMUM LOAD BED CAPACITY
11.  DO NOT RIDE IN LOAD BED
12.  DANGER OF EXPLOSION
DO NOT FILL GAS CAN IN LOAD BED
13.  WARNING
MAXIMUM LOAD & CENTER OF GRAVITY.
KEEP LOAD AS FAR FORWARD AS POSSIBLE.
DO NOT RIDE IN LOAD BED
14.  KEEP HANDS & FINGERS AWAY FROM DUMP BED.
DO NOT STAND BEHIND DUMP BED

Read all of SAFETY and this section before attempting any procedure. Pay particular attention to Notices, Cautions, Warnings and Dangers.

- | | | | | | |
|-----|---|--|-----|---|---|
| 15. |  | CLEAN UP GASOLINE SPILLS WITH WATER BEFORE STARTING ENGINE | 28. |  | DO NOT DISPOSE OF BATTERIES IN LANDFILL |
| 16. |  | UNLEADED GASOLINE | | | |
| 17. |  | DO NOT SPILL FUEL ON A HOT ENGINE | 29. |  | DO NOT DRIVE ON HIGHWAY |
| 18. |  | GROUND FUEL PUMP | | | |
| 19. |  | LOW OIL PRESSURE | 30. |  | WINDSHIELDS DO NOT PROVIDE PROTECTION FROM FLYING OBJECTS |
| 20. |  | NEGATIVE GROUND BATTERY | 31. |  | BATTERIES ARE HEAVY. USE CARE LIFTING |
| 21. |  | DO NOT CONNECT POSITIVE BATTERY TERMINAL TO GROUND | 32. |  | USE INSULATED TOOLS |
| 22. |  | SHORTING BATTERY TERMINALS MAY CAUSE EXPLOSION | 33. |  | WEAR EYE PROTECTION |
| 23. |  | NO TAMPERING. KEEP HANDS OUT | | | |
| 24. |  | WARNING CORROSIVE | 34. |  | NO SMOKING |
| 25. |  | WARNING EXPLOSIVE | 35. |  | HOT SURFACE |
| 26. |  | WARNING LETHAL VOLTAGE | | | |
| 27. |  | DO NOT EXPOSE TO FLAME | 36. |  | OPERATE FROM DRIVERS SIDE ONLY |

SAFETY

Read all of SAFETY and this section before attempting any procedure. Pay particular attention to Notices, Cautions, Warnings and Dangers.

Notes:

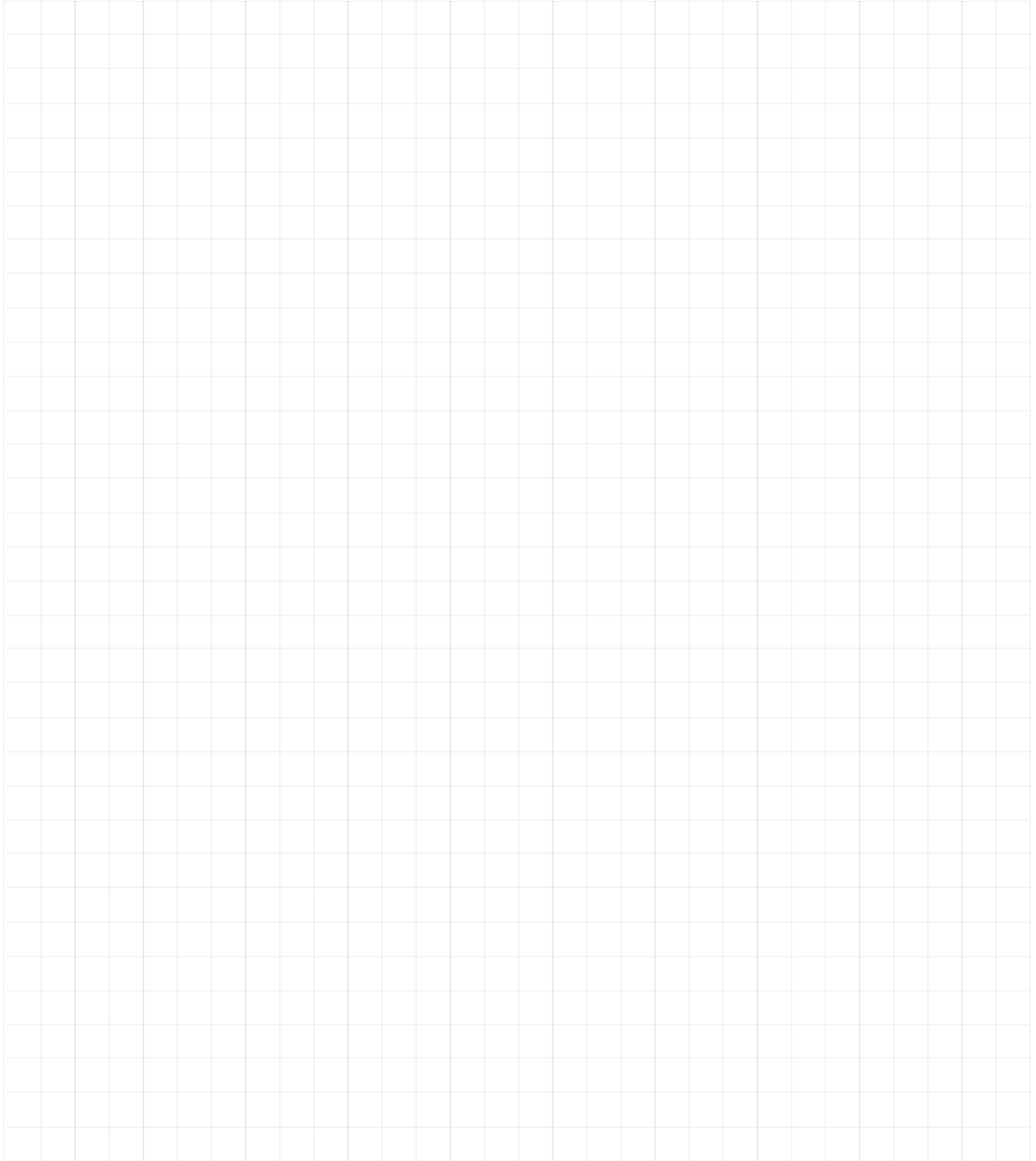
A large grid of graph paper for taking notes, consisting of 20 columns and 30 rows of small squares.

GENERAL SPECIFICATIONS

Read all of SAFETY and this section before attempting any procedure. Pay particular attention to Notices, Cautions, Warnings and Dangers.

GENERAL SPECIFICATIONS



CUSHMAN

MODEL: REFRESHER® FS4
TYPE: GASOLINE POWERED REFRESHMENT VEHICLE
MODEL YEAR: 2014
Part No: 639075



PRODUCT SPECIFICATION

CONFIGURATION HIGHLIGHTS

Refresher Unit Overview: Refresher unit designed for inventory of unopened, pre-packaged, non-perishable foods for distribution through daily use. This Refresher unit is not meant for long term food storage or storage of opened food and beverage items. Adherence to local food handling regulations.

Each Refresher Unit Consist Of: Windshield with Frame; Struts and Slate Canopy; 4 Insulated Sliding Drawers with Locks; Slide out Trash/recycle storage bin system, 2 plastic removable bins; Lower Rear Corner Storage Sections - both sides of endcap; Locking System for Holding & Changing Modules; Polar White Counter top; Left & Right Side Mirrors.

Accessories: Drawer Dividers (2); Consumable Ice Bin (1); Candy & Sandwich Tray (1).

Modules: 6" Snack module with one dual-sided pullout polycarbon pegboard, hooks (6), baskets (2) and chip strips (2); 18" Display Module with 4 adjustable shelves; 18" Cup & Display Module with 2 adjustable shelves/1 cup tray with 4 slots/1 beverage box.

Upper Rear Endcap: Reversible insert for airports and bottles; 3.0 liter airports (2); shelves for napkins and bottles on back panel (3); shelves on inside of doors (6); Coffee/Creamer serving caddy (2).

Engine: 13 hp (9.7 kW) Exceeds SAE J1940 Standard, 4 cycle, 24.5 ci (401 cc) single cylinder, air-cooled by Kawasaki

- **Valve Train:** Overhead valve
- **Lubrication:** Pressurized oil system, spin-on oil filter
- **Balancer:** Internal counter rotating balance shaft
- **Fuel System:** Fixed float bowl with remote pulse fuel pump
- **Ignition:** Electronic spark/magneto
- **Air Cleaner:** Replaceable dry cartridge

Electrical: Starter/Generator, solid-state regulator, 12 Volt maintenance free battery (425 CCA, 60 minute reserve)

Drive Train: Automatic, continuously variable transmission (CVT)

Brakes: Dual rear wheel mechanical self-adjusting drum brakes. Single point park brake release with self-compensating system

Transaxle: Differential with helical gears, ground speed governor, forward/reverse

Canopy: Sunbrella®

Beverage Unit: 5000 Series Aluminum, Super Durable TGIC Polyester Powder Coating

Beverage Unit Storage Capacity:

- **Cold Storage Cabinets:** 4
- **Merchandising Capacity:** 21.1 cu ft (.59 m³)
- **Trash Bin Volume:** 3.4 cu ft (0.96 m³)
- **Work Space:** 13 ft² (4 m²)

PRODUCT OVERVIEW

Dimensions

Overall Length	147 in (366 cm)
Overall Width	54 in (137 cm)
Overall Height (No Canopy)	49 in (124 cm) (Top of steering wheel)
Overall Height (With Canopy)	80 in (203 cm)
Wheel Base	93.5 in (235 cm)
Front Wheel Track	39.6 in (100 cm)
Rear Wheel Track	39.5 in (100 cm)
Gnd Clearance @ Differential	4.5 in (11 cm)

Vehicle Power

Power Source	4 Cycle 24.5 cu in (401 cc)
Valve Train	Single Cylinder OHV
Horsepower (kW)	13 hp (10.1 kW) Exceeds SAE J1940 Std.
Electrical System	Starter/Generator. Solid State Regulator
Batteries (Qty, Type)	One, 12 Volt Maintenance Free
Key or Pedal Start	Pedal
Air Cleaner	Industrial Rated Dry Filter
Lubrication	Pressurized Oil System
Oil Filter	Spin-On
Cooling System	Air Cooled
Fuel Capacity	6.2 Gallon (23.5 L) early production tank
Fuel Capacity	5.2 Gallon (19.8 L) early production tank
Drive Train	Continuously variable transmission (CVT)
Transaxle	Differential with helical gears
Gear Selection	Forward-Reverse
Rear Axle Ratio	17.2:1 (Forward) 17.1:1 (Reverse)

Some items shown may be optional equipment

Performance

Seating Capacity	1 Person Std, 2 Persons Optional
Dry Weight	1470lb (661 kg)
Curb Weight	1508 lb (684 kg)
Vehicle load capacity	1015 lb (460 kg)
Outside Clearance Circle	Left 26.8 ft (8.1 m), Right 25.2 ft (7.6 m)
Intersecting Aisle Clearance	N/A
Speed (Level Ground)	Fwd - 12 mph +/- 0.5 mph (19 kph +/-0.8 kph) Rev - 11 mph +/- 0.5 mph (17 kph +/-0.8 kph)

Towing Capacity

N/A

Steering & Suspension

Steering	Self-compensating rack and pinion
Front Suspension	Leaf springs with hydraulic shock absorbers
Rear Suspension	Heavy Duty leaf springs with hydraulic shocks
Service Brake	4 Wheel hydraulic, front disc/rear drum
Parking Brake	Mechanical hand brake
Front Tires	Load Star 205/65-10
Rear Tires	Load Star 205/65-10

Body & Chassis

Frame	Welded steel with DuraShield™ powder coat
Front Body & Finish	Injection molded TPO
Rear Body & Finish	Steel. Base coat/clear coat
Standard Color	Forest Green

Noise & Vibration

Noise	Sound pressure; continued A-weighted equal to or less than 76 db(A).
Vibration, WBV	Highest RMS value of weighted acceleration is less than 2.5 m/s ² .
Vibration, HAV	Highest RMS value of weighted acceleration is less than 2.5 m/s ² . The uncertainty of measurement is 1.08 m/s ²

Measurement methods were applied per the ISO 2631 and ISO 5349 standards under conditions of typical vehicle surfaces.

GENERAL SPECIFICATIONS

Read all of SAFETY and this section before attempting any procedure. Pay particular attention to Notices, Cautions, Warnings and Dangers.



CUSHMAN

Refresher Unit Dimensions

Refresher Unit Length	66.5 in (169 cm)
Refresher Unit Width	51 in (130 cm)
Refresher Unit Height	55.5 in (140 cm)
Refresher Unit Weight	565 lb (256kg)
Canopy	Sunbrella®
Standard Color	Pebble Platinum
Canopy	Slate Canopy
Standard Module Configuration	42" (106 cm) Total Capacity: - 6" (15.2 cm) Snack Pull Out - 18" (35.7 cm) Module with Adjustable Shelves - 18" (35.7 cm) Cup & Display Module

Refresher Unit Dimensions Cont.

Maximum Merchandising Capacity	21.1 cu ft (.59 m3)
Cold Storage Drawer Vol. (Total)	11.1 cu ft (0.31 m3)
Cold Storage Drainage	Single Drain Per Drawer
Cold Storage Capacity	12 oz cans: 400
Trash Bin Volume	3.4 cu ft (0.96 m3)
U Shaped Work Space	13 ft2 (1.2 m2)
Beverage Unit	5000 Series Aluminum - TGIC Polyester Powder Coating - Visible Product Doors w/Locks

OPTIONS & FIELD INSTALLED ACCESSORIES (Installation not included)*

Item	Std	Opt	Fld	Item	Std	Opt	Fld
Refresher Unit				TIRES & WHEELS:			
Base Unit, for FS4 - Pebble Platinum	X			Front & Rear:			
Base Unit, for FS4 - Desert Stone		X		Load Star 205/65-10	X		
Canopy - Slate (standard for Pebble Platinum unit)	X			Wheel Covers:			
Canopy - Walnut Tweed (standard for Desert Stone unit)		X		10" Chrome		X	
Canopy - Additional Color Options		X	X	COLORS:			
Refresher Countertop - Polar White	X			Body Color Forest Green	X		
Refresher Countertop - Mercury Gray, Sand Shade		X		Body Color Ivory		X	
End Cap with Trash & Recycle	X			Body Color White		X	
Windshield	X			Body Color Yellow		X	
Side Mirrors	X			Body Color Orange		X	
Refresher Accessories				Body Color Black		X	
6" Snack Module with Hooks Kit	X		X	Body Color Platinum		X	
6" Cup Holder Module - 5 internal Racks			X	Body Color Blue		X	
12" Snack Module with Hooks Kit			X	Custom Body Color (upon request)		X	
12" Module with 4 Adjustable Shelves			X	Seating:			
12" Standard Shelves - 2 Pack			X	Seat Color (Gray) Driver Only	X		
12" Wedge Shelves - 2 Pack			X	Seat Color (Gray) Driver & Pass		X	
12" Single Airpot Holder -White			X	Additional Seat Colors: Tan, White or Black		X	
18" Module with 4 Adjustable Shelves	X		X	OTHER PERFORMANCE:			
18" Cup & Display Module	X		X	Ash Tray			X
18" Standard Shelves - 2 Pack			X	Front Bumper & Guard (Black)	X		
18" Wedge Shelves - 2 Pack			X	Limited Slip Differential			X
18" Dual Airpot Holder - White			X	High Altitude Jetting 3 - 6K ft (900 - 1800 m)			X
18" Food Warmer Module			X	High Altitude Jetting 6K + ft (1800 + m)			X
24" Keg Module			X	Horn	X		
Food Warmer Bags			X	Low Oil Indicator	X		
Consumable Ice Drawer Insert, SS, 10x10x20	X		X	Glove Box Door (Locking) Driver & Passenger Sides			X
3.0 Liter Airpot (2 Standard)	X		X	Glove Box Door (Locking) Driver Side			X
Reversible Insert For Airpots/Bottles	X		X	Glove Box Door (Locking) Passenger Side			X
Napkin & Bottle Holder Shelves - 3 Pack w/Hardware	X		X	ELECTRICAL:			
Coffee/Creamer Serving Caddy - 2 Pack	X		X	Brake Lights			X
Mini Bottle Holder Shelves - 3 Pack w/Hardware	X		X	Headlights	X		
Drawer Inserts: Candy & Sandwich Tray - 2 Pack			X	LED Headlights			X
Snack Module Kit (6HKS, 2 Clip Strips, 2 Baskets)			X	Turn Signals with 4-Way Flashers			X
Mini Tray Set - 3 Pack			X	Unique Individual Key Switch			X
Humidor			X	12 Volt Outlet			X
Drawer Dividers	X		X	Hour Meter			X

GENERAL SPECIFICATIONS

Read all of SAFETY and this section before attempting any procedure. Pay particular attention to Notices, Cautions, Warnings and Dangers.

VEHICLE DIMENSIONS

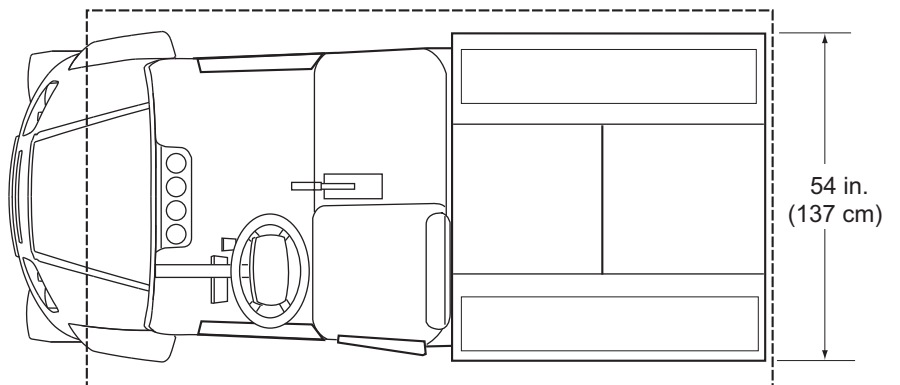
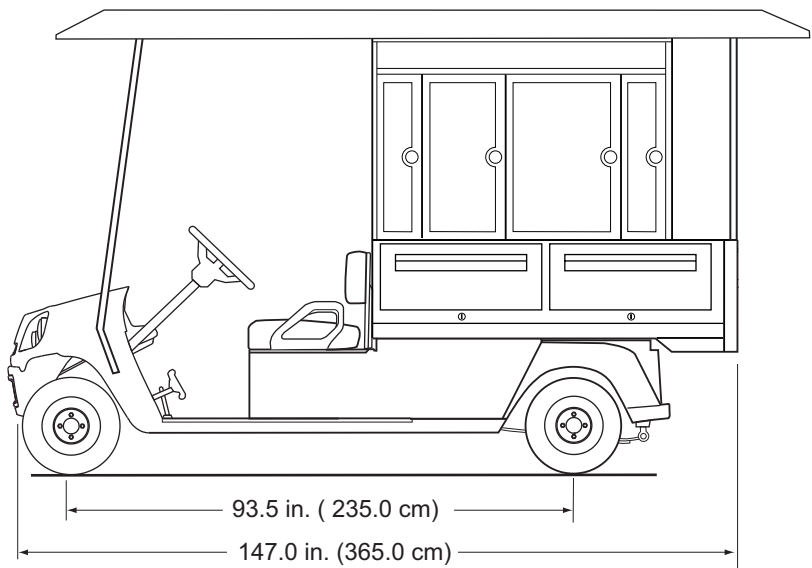
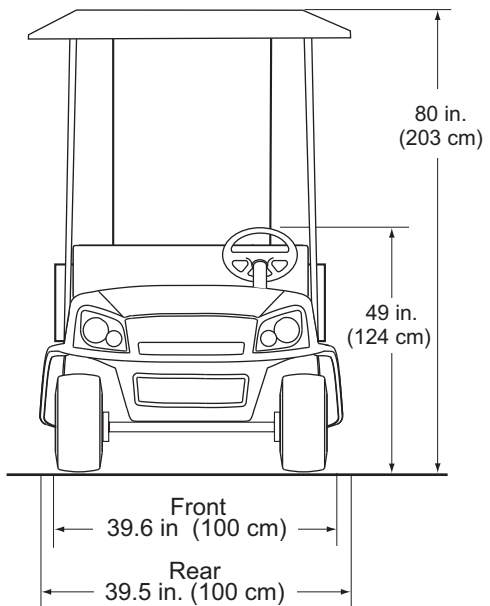

GENERAL SPECIFICATIONS

Read all of SAFETY and this section before attempting any procedure. Pay particular attention to Notices, Cautions, Warnings and Dangers.

TURNING DIAMETER AND INCLINE INFORMATION

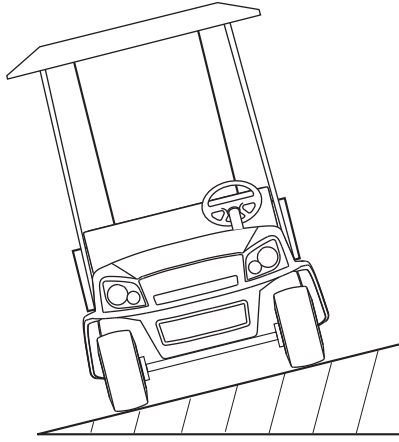

RECOMMENDED MAX SIDE TILT
25% or 14° MAX

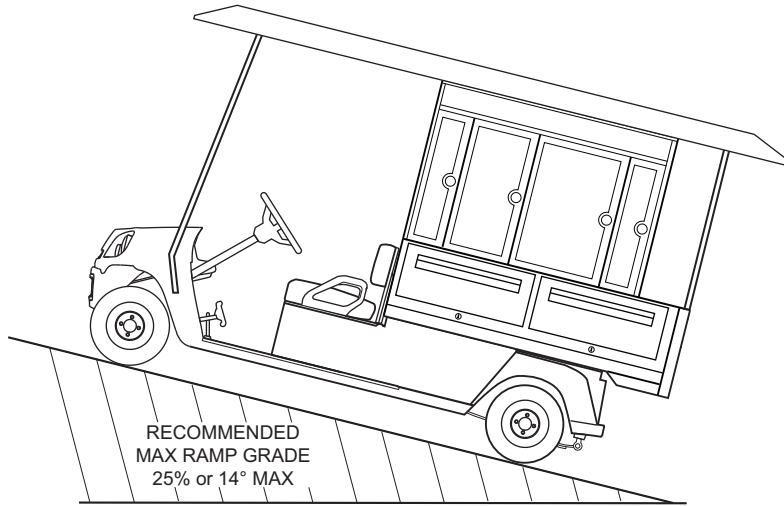

RECOMMENDED
MAX RAMP GRADE
25% or 14° MAX

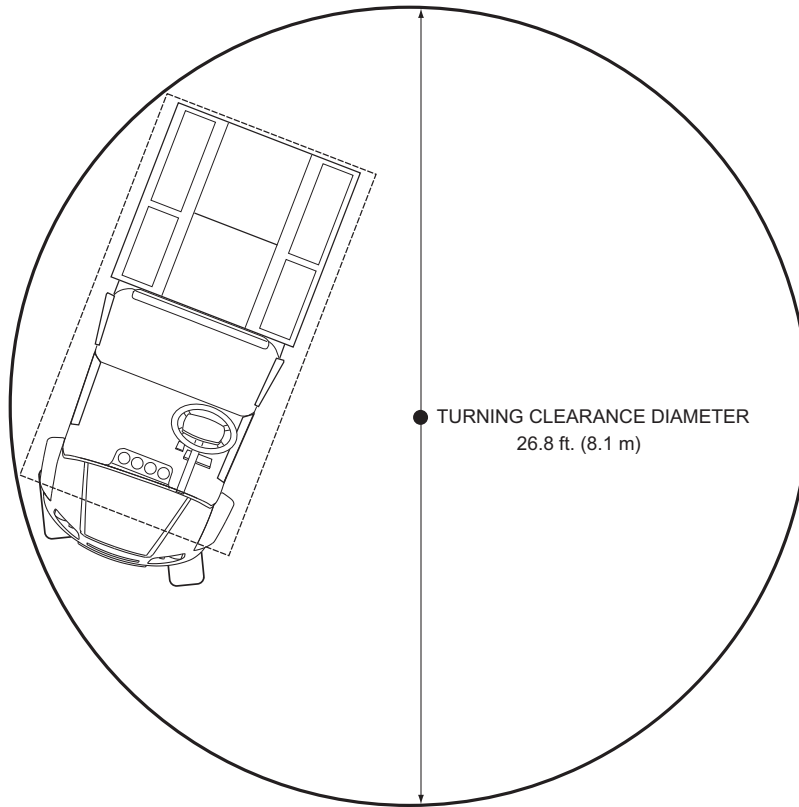

● TURNING CLEARANCE DIAMETER
26.8 ft. (8.1 m)

Read all of SAFETY and this section before attempting any procedure. Pay particular attention to Notices, Cautions, Warnings and Dangers.

Notes:

A large grid of graph paper for taking notes, consisting of 20 columns and 30 rows of small squares.

GENERAL SPECIFICATIONS

Read all of SAFETY and this section before attempting any procedure. Pay particular attention to Notices, Cautions, Warnings and Dangers.

Notes:

A large grid of graph paper for taking notes, consisting of 20 columns and 30 rows of small squares.

Read all of SAFETY and this section before attempting any procedure. Pay particular attention to Notices, Cautions, Warnings and Dangers.

INTRODUCTION

REFRESHER FS4 VEHICLE OVERVIEW

The Refresher FS4 unit is designed for inventory of unopened, pre-packaged, non-perishable foods for distribution through daily use. It is not intended for long term food storage or storage of opened food and beverage items. Adherence to local food handling regulations is required.

Please read the entire manual to become thoroughly familiar with this vehicle and the Refresher unit. Pay particular attention to all Notices, Cautions, Warnings, and Dangers.

Refer to Operating Instructions and Maintenance sections of this manual for more information specific to the Refresher FS4 unit.

Refresher FS4 Unit Weight (Empty): 595 lbs. (270 kg)

Food/Beverage Maximum Capacity: 1,015 lbs. (460 kg)

VEHICLE FEATURES

General Information

NOTICE

If vehicle is equipped with factory installed custom accessories, some accessories remain operational with the key switch in the 'OFF' position.

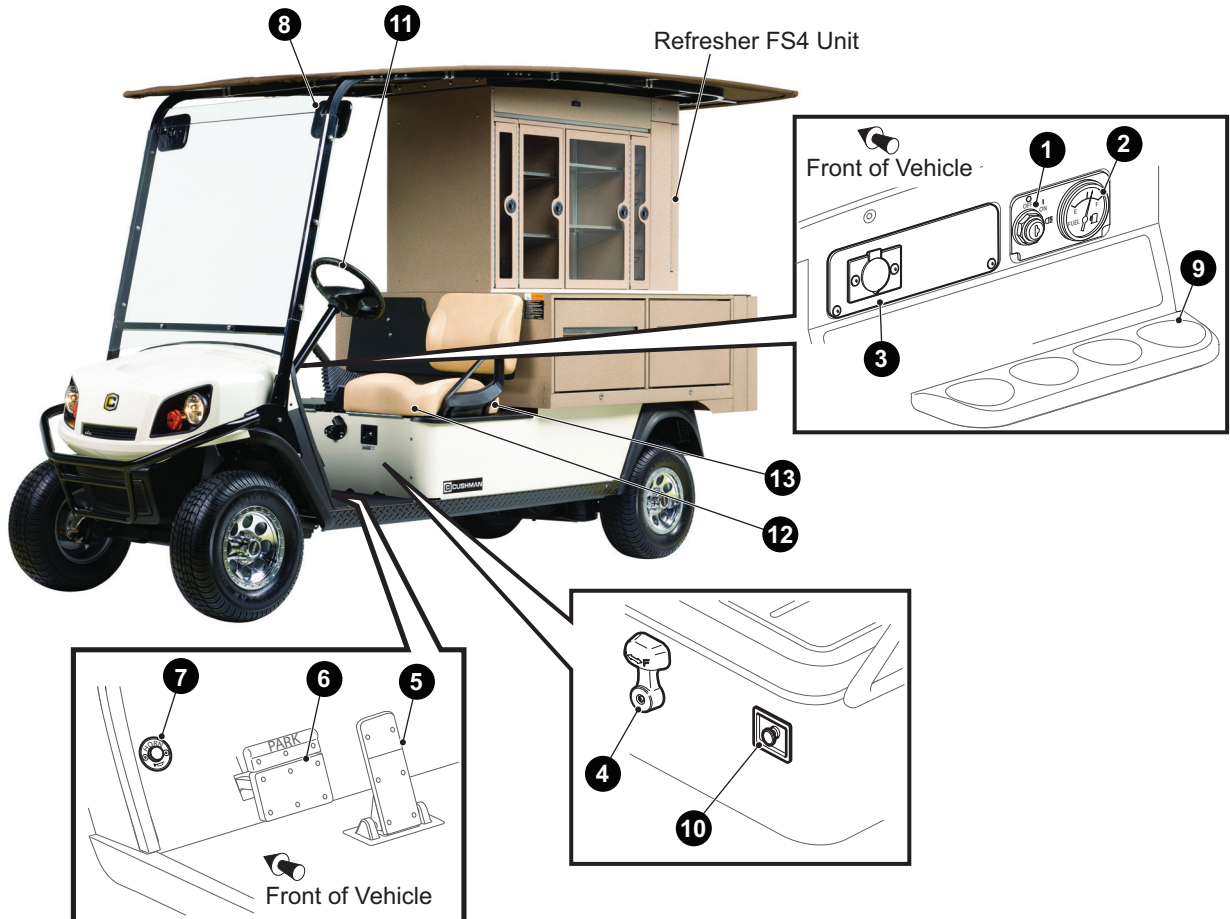

INTRODUCTION

Read all of SAFETY and this section before attempting any procedure. Pay particular attention to Notices, Cautions, Warnings and Dangers.

1. Key / Light Switch

Located on the dash panel, the combination key/light switch controls the basic electrical system of the vehicle, as well as the front and rear lights. The switch has three positions; OFF, ON, and LIGHTS.

2. Fuel Gauge with Low Oil Pressure Indicator

The fuel gauge indicates the amount of gasoline in the fuel tank. 'F' indicates a full tank and 'E' indicates an empty fuel tank. The fuel gauge has a low oil pressure indicator. A low engine oil pressure condition is shown with an indicator light.

The low oil pressure indicator light on early model vehicles is located beside the fuel gauge on the dash, and not part of the fuel gauge.

3. 12V Outlet

The 12 volt outlet is located above the cupholder and is protected by a removable cover. It allows use of electronic devices such as cell phone, GPS, etc.

4. Direction Selector

Located on the seat wrap panel, the direction selector permits the selection of either 'F' (forward), 'R' (reverse) or 'N' (neutral). A reverse warning buzzer will activate when moved to the "R" position.

5. Accelerator Pedal

The accelerator pedal is on the floorboard to the right of the brake pedal. Its function is to accelerate and control the speed of the vehicle.

6. Brake and Park Brake

The brake pedal is located on the floor to the left of the accelerator pedal. The brake pedal is a combination brake and park brake. The brake pedal function is to slow or stop the vehicle. When engaged, the park brake prevents the vehicle from rolling.

7. Horn

The horn button is located on the driver side floorboard, and activates the horn when pressed.

8. Rear View Mirror

Rear view mirrors are attached to the front struts at each side of the windshield.

9. Cup Holder

A cup holder is provided for the convenience of both the driver and passenger.

10. Choke

Located on the seat wrap panel, the choke function is to aid with cold starting.

11. Steering Wheel

The steering wheel, located in front of the driver seat, is used to control the vehicle direction of travel.

12. Seat

The vehicle is equipped with an operator seat; it is not designed to carry more than one occupant.

13. Hip Restraint

The hip restraint is designed to keep the operator properly positioned in the event of sudden vehicle position changes.

14. Glove Box

Glove box compartments, one on each side of the instrument panel, provide storage space for small items. Glove box may be equipped with optional doors.

Read all of SAFETY and this section before attempting any procedure. Pay particular attention to Notices, Cautions, Warnings and Dangers.

Notes:

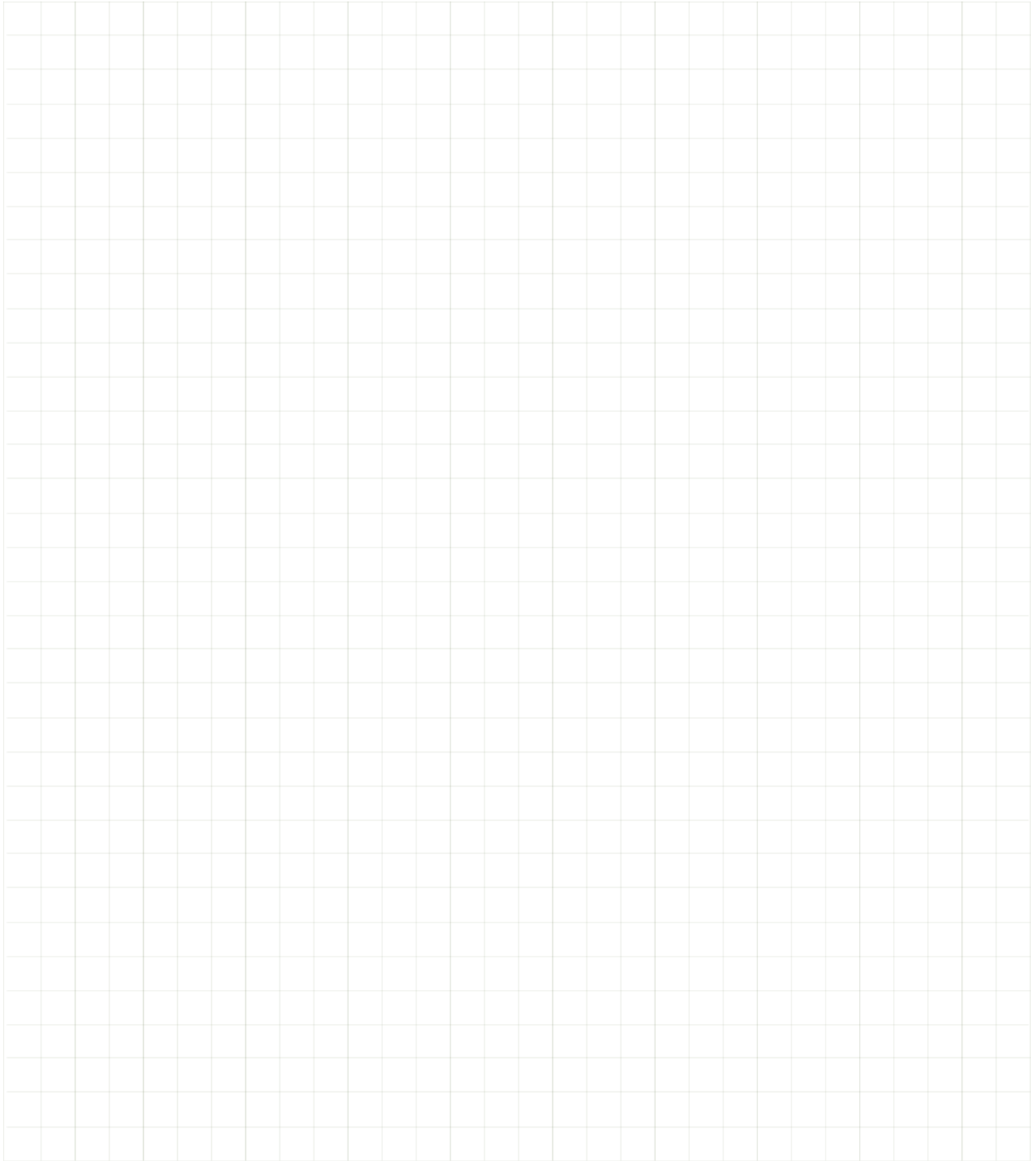
A large grid of graph paper for taking notes, consisting of 20 columns and 30 rows of small squares.

INTRODUCTION

Read all of SAFETY and this section before attempting any procedure. Pay particular attention to Notices, Cautions, Warnings and Dangers.

Notes:

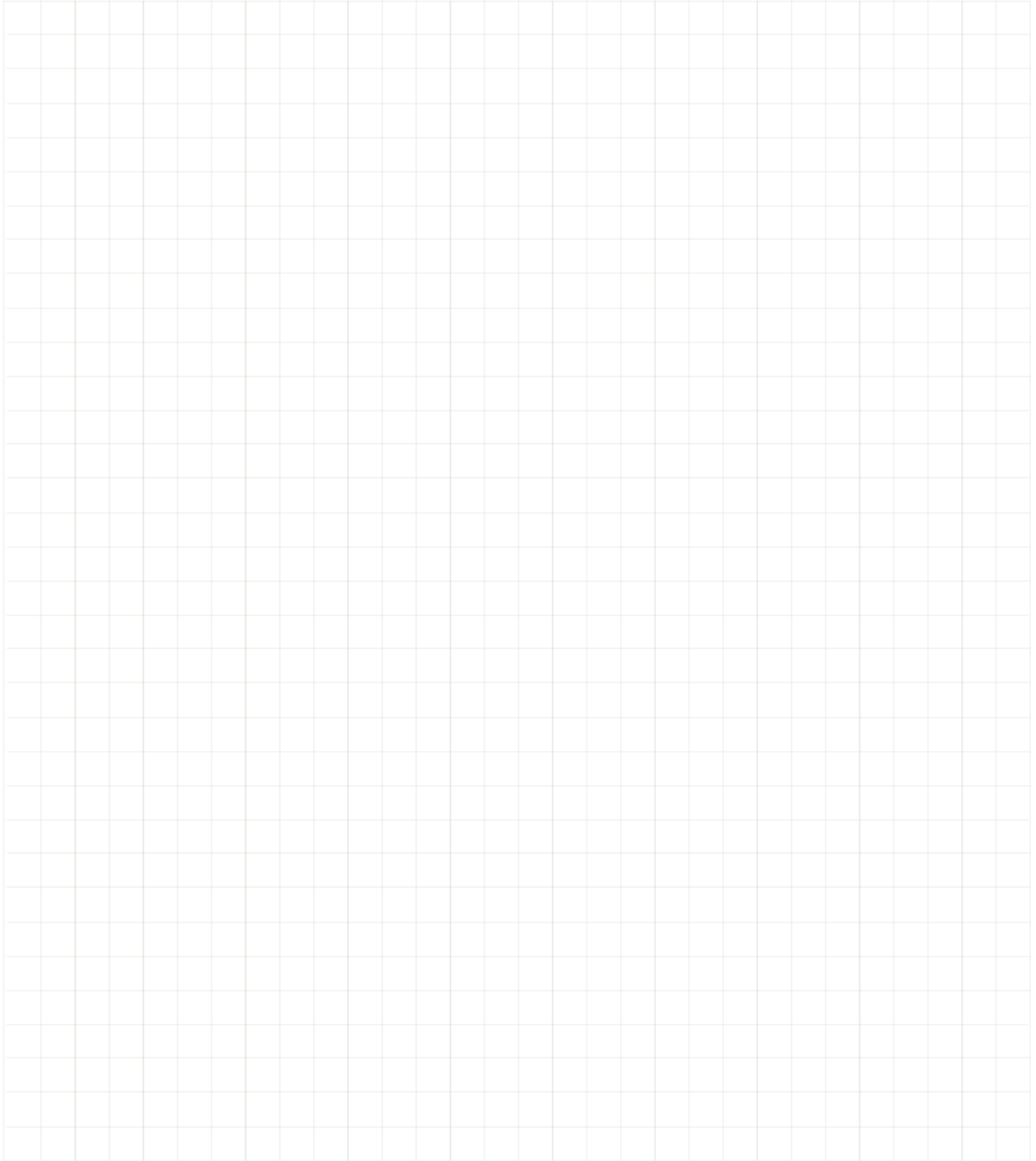
A large grid of graph paper for taking notes, consisting of 20 columns and 30 rows of small squares.

Read all of SAFETY and this section before attempting any procedure. Pay particular attention to Notices, Cautions, Warnings and Dangers.

OPERATING PROCEDURES

SERIAL NUMBER LOCATION

Three serial number and manufacture date code labels are on the vehicle. Part 'A' and 'B' are located on the crossmember section of the chassis on the driver side. Part 'C' is placed below the driver side of the seat underneath the choke intake adapter. And part 'D' is placed on the rear frame cross tube.

Design changes take place on an ongoing basis. In order to obtain correct components for the vehicle, the manufacture date code, serial number and vehicle model must be provided when ordering service parts.

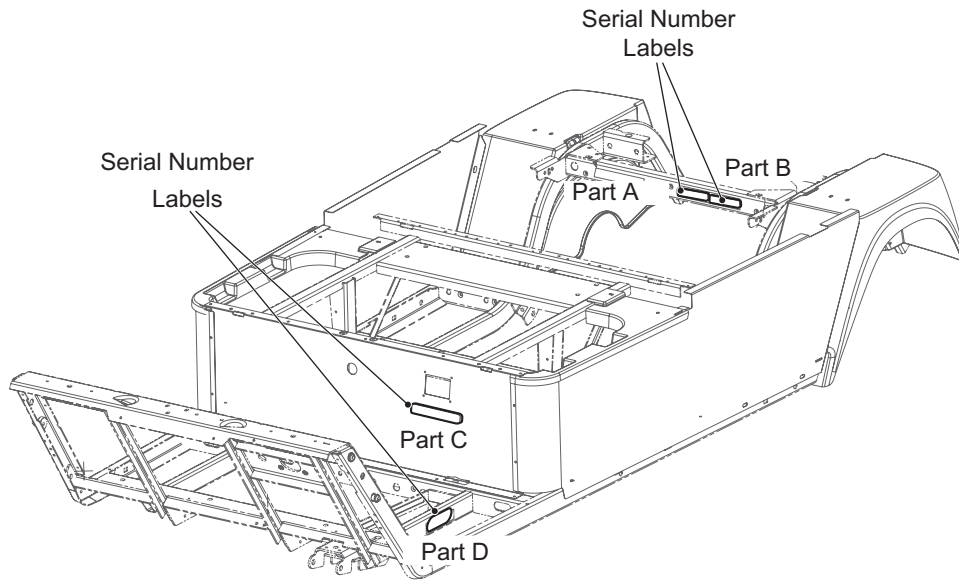

PART A			Augusta Georgia, USA	
	<small>GOLF, TURF & SPECIALTY PRODUCTS</small>		1 800 241-5855	
	MODEL	_____		
	DATE CODE	_____		
	SERIAL No.	_____		
	Bar Code	_____		
		Lb / kg W Batt	_____	
		Nom Power Hp / kw	_____	
		Label No.	_____	
PART B	Rated Capacity W/Operator lb/kg	/	System voltage	V
	Lb/kg W/O Batt	/	Max Draw bar lb/kg	/
	Max Batt lb/kg	/		

PART C/D	SERIAL No. _____			
	Bar Code _____			

OPERATING PROCEDURES

Read all of SAFETY and this section before attempting any procedure. Pay particular attention to Notices, Cautions, Warnings and Dangers.

BEFORE INITIAL USE

Read and follow the safety label on the instrument panel. Be sure to understand safe operation of the vehicle and its equipment.

WARNING

Hydrogen gas is generated as a natural part of the lead acid battery charging process. A 4% concentration of hydrogen gas is explosive and could cause severe injury or death. Charging must take place in an area that is adequately ventilated (minimum of 5 air exchanges per hour).

To reduce the chance of battery explosion that could result in severe injury or death, never smoke around or charge batteries in an area that has open flame or electrical equipment that could cause an electrical arc.

Before a new vehicle is put into operation, the items shown in the **INITIAL SERVICE CHART** must be performed.

Vehicle battery must be fully charged before initial use.

Check for correct tire inflation (45 - 55 psi (310 - 379 kPa)).

Check for oil or fuel leaks that could have developed in shipment from the factory.

Determine and record braking distance required to stop vehicle for future brake performance tests.

Remove the clear plastic (used to provide protection during shipping) from the seat.

ITEM	SERVICE OPERATION
Battery	Charge battery
Seats	Remove protective plastic covering
Brakes	Check operation and adjust if necessary
	Check hydraulic brake fluid level if equipped
	Establish acceptable stopping distance
Tires	Check air pressure (45 - 55 psi (310 - 379 kPa))
Fuel	Fill tank with correct fuel
Engine	Check oil level

INITIAL SERVICE CHART

OPERATING THE VEHICLE

CAUTION

Improper use of vehicle or lack of proper maintenance may result in damage or decreased performance.

Read and understand the following warnings before attempting to operate the vehicle.

WARNING

To reduce the possibility of severe injury or death resulting from loss of vehicle control, the following warnings must be observed:

When driving vehicle, consider the terrain, traffic conditions and the environmental factors which effect the terrain and the ability to control the vehicle.

Vehicle is intended for use on improved surfaces.

Use extra care and reduced speed when driving on poor surfaces, such as loose dirt, wet grass, gravel, etc.

Stay in designated areas and avoid extremely rough terrain.

Read all of SAFETY and this section before attempting any procedure. Pay particular attention to Notices, Cautions, Warnings and Dangers.

Maintain a safe speed when driving downhill. Use the service brake to control speed when traveling down an incline. A sudden stop or change of direction may result in loss of vehicle control.

Slow down before and during turns. All turns should be made at reduced speed.

Never drive vehicle up, down, or across an incline that exceeds 14° (25% grade).

To reduce the possibility of severe injury or death resulting from improper vehicle operation, the following warnings must be observed:

Refer to GENERAL SPECIFICATIONS for seating capacity.

Pressing accelerator pedal will release foot operated park brake and may cause inadvertent vehicle movement. Turn the key to the 'OFF' position whenever the vehicle is parked.

To prevent inadvertent movement when the vehicle is to be left unattended, engage the park brake, move direction selector to forward position, turn key to 'OFF' position and remove it from switch.

Make sure direction selector is in correct position before attempting to start vehicle.

Always bring vehicle to a complete stop before shifting direction selector.

Do not take vehicle out of 'gear' while in motion (coast).

Check area behind vehicle before operating in reverse.

All occupants must remain seated while vehicle is moving. Keep entire body inside vehicle and hold on while vehicle is in motion.

Run-In

Check for oil or fuel leaks that could have developed in shipment from the factory. Avoid full throttle starts and rapid acceleration until the engine has achieved operating temperature.

All engines consume more oil than normal during the first hours of operation. As internal moving parts are run-in, oil consumption should gradually decrease until the rate of consumption stabilizes.

Check the oil level per the MAINTENANCE section. Add oil if necessary.

Cold Starting

Starting a cold engine **may** require use of the choke. Press the accelerator approximately 1" (2.5 cm) or until the starter just begins to operate. Pull choke out if required. Accelerate slowly and push choke in completely when engine runs smoothly.



CAUTION

Do not allow starter to operate continuously for more than 10 seconds. Allow 30 seconds between starting attempts. If the vehicle does not start on the third attempt, turn the key switch to 'off', engage park brake and determine cause of problem.

If the vehicle had been running and the engine will not start within 10 seconds, use the choke to help start.

OPERATING PROCEDURES

Read all of SAFETY and this section before attempting any procedure. Pay particular attention to Notices, Cautions, Warnings and Dangers.

STARTING AND DRIVING

WARNING

To reduce the possibility of roll-back, which could result in severe injury or vehicle damage, do not release service brake until the engine has started.

To operate vehicle:

1. Press service brake pedal, place key in switch, and turn key to 'ON' position.
2. Move direction selector to desired direction.
3. Release park brake by pressing the service brake pedal until the park brake releases.
4. Slowly press accelerator pedal to start the engine. Release service brake when engine starts.
5. When accelerator pedal is released, the ignition circuit is de-energized and the engine stops. To stop the vehicle more quickly, press the service brake pedal.

NOTICE

When the direction selector is in the reverse position, a warning signal will sound to indicate that the vehicle is ready to run in reverse.

Starting the Vehicle on a Hill

WARNING

To reduce the possibility of roll-back, which could result in severe injury or vehicle damage, do not release service brake until engine has started.

CAUTION

Use the brake pedal to hold vehicle on a hill. Do not hold vehicle on hill using accelerator and engine. This will cause premature and excessive wear to drive train components.

To reduce the possibility of permanent damage to the drive system, it is important to prevent excessive roll-back when starting the vehicle on a hill.

Place left foot on service brake and release the park brake. Press accelerator with right foot and release the service brake by lifting left foot.

Coasting

WARNING

To reduce the possibility of severe injury or death from coasting at above recommended speeds, limit speed with service brake.

On steep hills, it is possible for the vehicle to coast at faster speeds than those attainable on a flat surface. To reduce possible loss of vehicle control and severe drive train damage, speeds should be limited to no more than the maximum governed speed on level ground (see GENERAL SPECIFICATIONS). Limit speed by applying service brake.

Read all of SAFETY and this section before attempting any procedure. Pay particular attention to Notices, Cautions, Warnings and Dangers.

Fuel

WARNING

To decrease the risk of severe injury or death from improper fuel handling:

Do not smoke near the fuel tank.

Do not add fuel near open flame or electrical items that can cause a spark.

Always handle gasoline in a well ventilated area.

Always wear eye protection to protect against splashed fuel and fuel vapors.

Inspect the fuel cap, tank and other components for leaks or damage that can cause a hazardous condition.

CAUTION

Oxygenated or reformulated gasoline, is mixed with alcohols or ethers. Excessive amounts of these blends can damage the fuel system or cause performance problems. If any operating problems occur, use gasoline with a lower percentage of alcohol or ether.

Use clean regular grade unleaded fuel. The Ethanol blend fuel up to 10% is permitted.

Do not use gasoline that contains methanol.

High altitude or heavy use/load applications can benefit from higher octane gasoline.

Fuel Tank

The fuel tank is found below the seat on the passenger side of the vehicle. Fill the tank with clean, automotive grade gasoline.

Early Production Fuel Tank

WARNING

Always allow enough space for the expansion of gasoline. Leave at least 1-inch (2.5 cm) of space below bottom of filler neck.

Early production fuel tanks can be identified by the location of the fuel cap which is located in the middle of the top of the tank as shown.

Early production fuel tanks require enough space for the expansion of the gasoline. Leave at least 1-inch (2.5 cm) of space below the bottom of the filler neck.

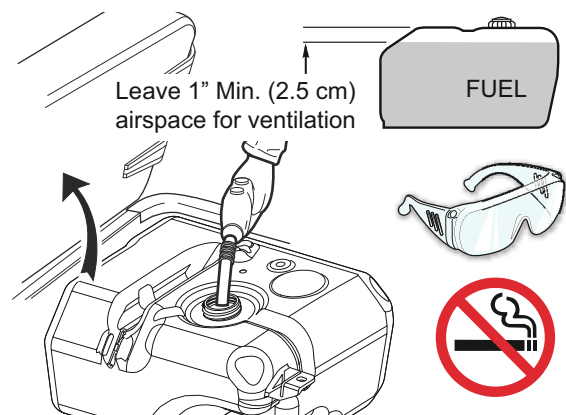

OPERATING PROCEDURES

Read all of SAFETY and this section before attempting any procedure. Pay particular attention to Notices, Cautions, Warnings and Dangers.

Late Production Fuel Tank

Late production fuel tanks can be identified by the location of the fuel cap which is located in the rear of the top of the tank as shown.

Late production fuel tanks are designed to allow for fuel expansion and do NOT require space below bottom of filler neck.

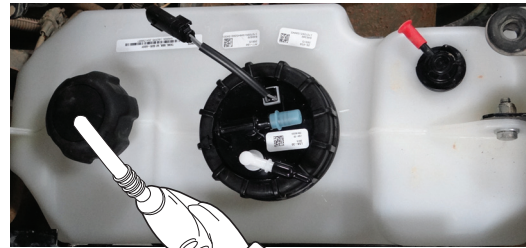

Late Production Fuel Tank

Battery

CAUTION

Excessive use of accessories may drain the battery and leave insufficient charge to start the vehicle.

The vehicle uses a combination starter/generator to both start the engine and charge the battery. The engine will not idle; therefore, the battery cannot be charged while the vehicle is stopped. Do not operate accessory items (such as lights) excessively while the vehicle is stopped.

The generator is capable of supplying 35 amps. Operation of multiple accessories could result in discharge of the battery even with the engine running and the generator operating. Discharging the battery is known as deep cycling. The battery is not a deep cycle model, but is a starting battery. Multiple deep cycling will result in the premature failure of the battery.

If the vehicle battery has become discharged, it can be charged using a 12 volt charger that is rated at 10 amps or less and in accordance with all instructions provided by the manufacturer of the charger.

12 Volt Power Outlet

CAUTION

Overuse of accessories may drain the battery and leave insufficient reserve to start the vehicle.

Vehicle may be equipped with an optional 12 volt power outlet. Outlet is rated at 15 amps, and is located to the left of key/light switch.

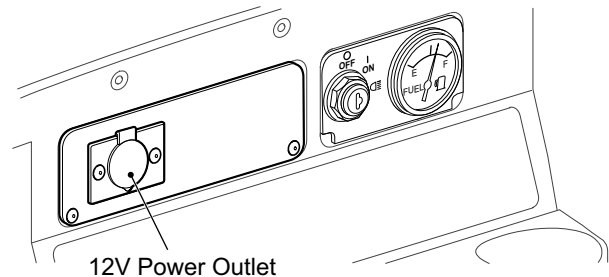

Canopy and Windshield

WARNING

The canopy does not provide protection from roll over or falling objects.

The windshield does not provide protection from tree limbs or flying objects.

Read all of SAFETY and this section before attempting any procedure. Pay particular attention to Notices, Cautions, Warnings and Dangers.

CAUTION

To prevent damage to the vehicle, do not hold on to sun top struts and stand on body panels.

The canopy and windshield provide some protection from the elements; however, they will not keep the operator and passenger dry in a downpour. This vehicle is not equipped with seat belts and the canopy has not been designed to provide roll over protection. In addition, the canopy does not protect against falling objects nor does the windshield protect against flying objects and tree limbs. Keep arms and legs inside of vehicle while it is moving.

REFRESHER VEHICLE OVERVIEW

The Refresher FS4 unit consists of:

- windshield with frame
- struts and canopy
- four (4) lockable, insulated, sliding drawers
- slide out trash compartment system
- two (2) removable plastic bins
- two (2) lower, rear, corner storage compartments
- locking system for holding and changing modules
- countertop
- left and right side mirrors
- 42" of module space to meet adjustable storage needs
- shelves in upper rear end-cap

The Refresher unit is designed for inventory of unopened, pre-packaged, non-perishable foods for daily distribution. It is not intended for long term food storage or storage of opened food and beverage items. Adherence to local food handling regulations is required.

Serial Number Location

The Refresher unit serial number is located on the inside of the right, rear door of the end cap.

Emissions Labels and Engine Access

A pull up plate is located beneath the lower side drawers for access to the engine compartment.

Slide side drawers out and set aside to expose pull up plate.

When reinstalling drawers, align both drawer hinges to the slides in the chassis. **DO NOT FORCE THIS INSTALLATION.** Use extreme caution when installing drawers to avoid damage to the slides.

The emission labels are visible when the engine compartment is accessed.

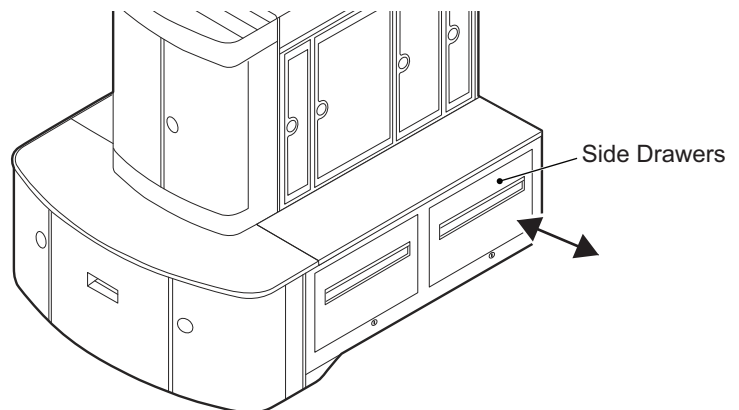

OPERATING PROCEDURES

Read all of SAFETY and this section before attempting any procedure. Pay particular attention to Notices, Cautions, Warnings and Dangers.

REFRESHMENT UNIT OPERATION

Lockdown Mechanism

1. **Countertop:** The passenger side countertop is removable for module replacement. To remove, lift countertop up and remove from hinge support. Removing the countertop allows the modules to slide out after releasing the module clamps (see next section for module clamp operation).

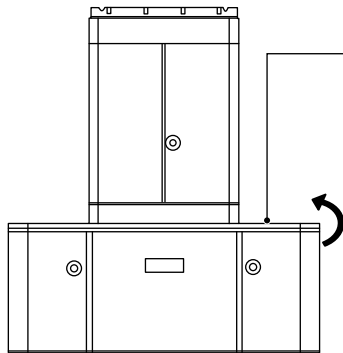

Lift up passenger side countertop and remove.

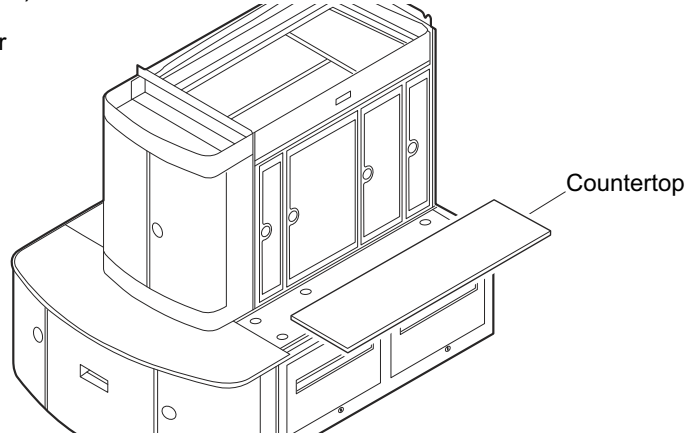

2. **Module Clamps:** The Refresher unit modules are secured by module clamp that place a downward force on the modules. Release the clamp by turning the rotating mechanisms on both sides of unit toward the left. Raise the clamp high enough so that a module can be lifted up and out of unit. The clamp must be released on BOTH sides of module before it can be removed from unit.

Module Clamp Release Mechanism

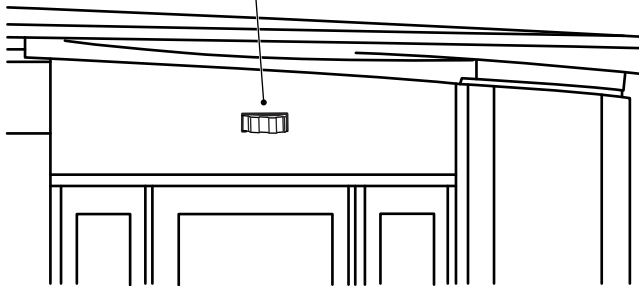

Clamp raises to release module.

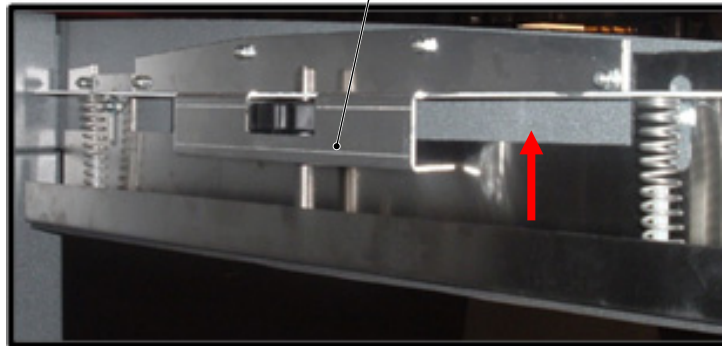

Module Removal and Installation

The standard FS4 unit features:

- One (1) 6" pull out module
- One (1) 18" cup and display module
- One (1) 18" display module with shelves

Units may be equipped with optional modules of various sizes and designs not specifically described in this manual. The basic removal and installation process for all modules is similar.

WARNING

The countertop and all modules must be properly installed before operating the vehicle.

Read all of SAFETY and this section before attempting any procedure. Pay particular attention to Notices, Cautions, Warnings and Dangers.

NOTICE

No tools are needed for module removal and installation.

Passenger side countertop must be removed and module clamps released prior to removal of any module.

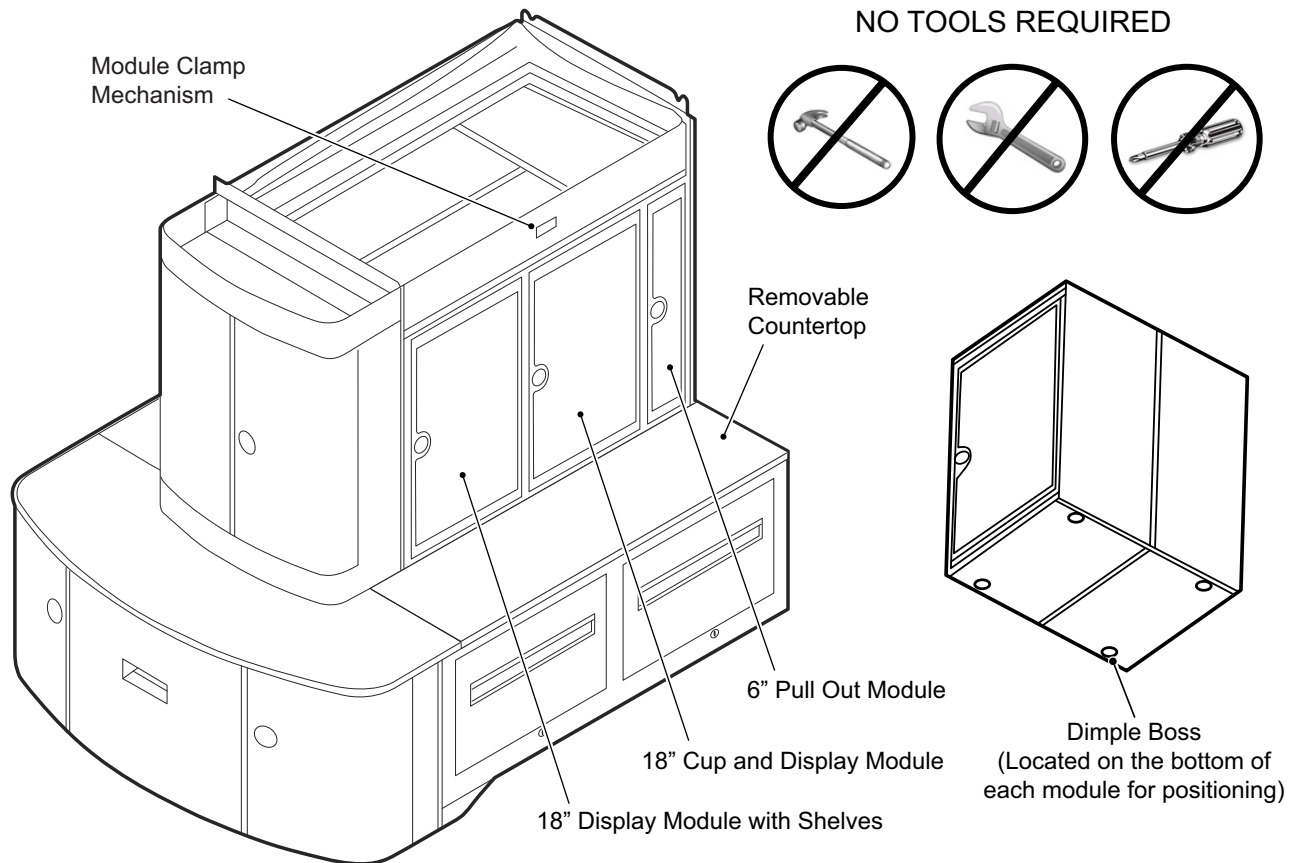

Standard modules shown.

All modules, including optional modules can be arranged in any combination totaling 42" wide.

1. **6" Pull Out Module:** The standard unit 6" pull out module and all other 6" modules are the same size and similar weight. Modules are positioned in place with four dimples on the bottom surface. To remove, remove the passenger

OPERATING PROCEDURES

Read all of SAFETY and this section before attempting any procedure. Pay particular attention to Notices, Cautions, Warnings and Dangers.

side countertop and release module clamps (refer to lock down mechanism). Gently pull the module up and out using the door handle and or top end of module.

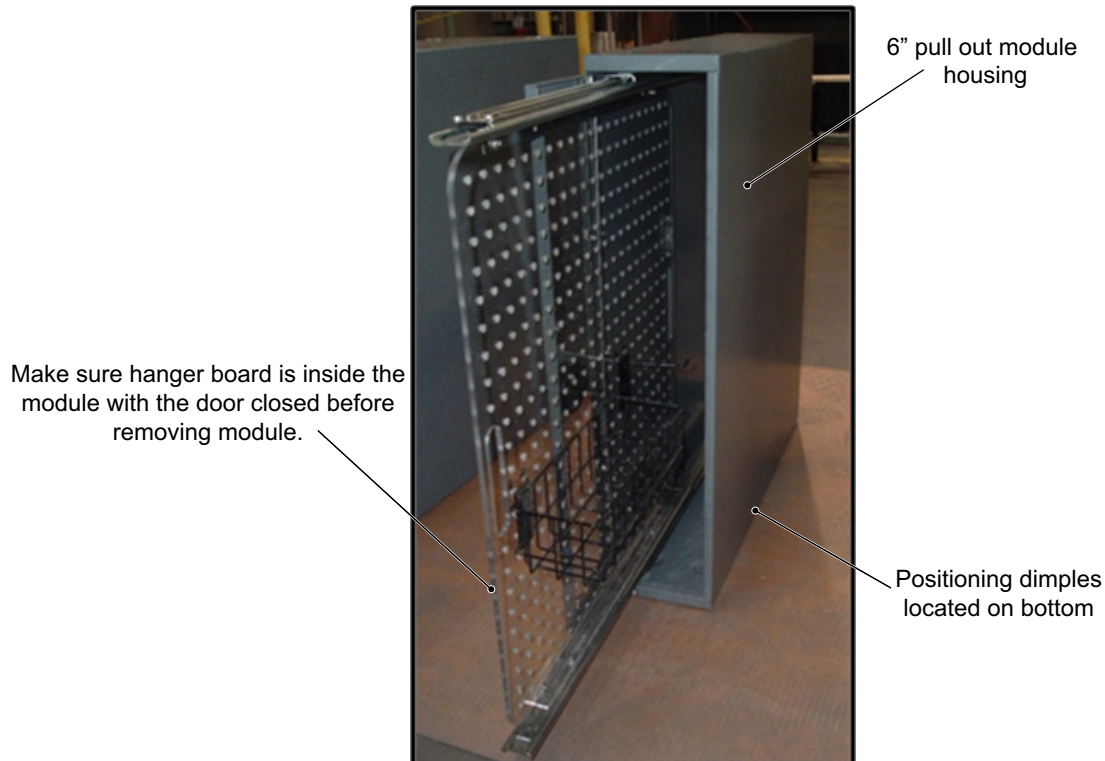

NOTICE

Passenger side countertop must be removed and module clamp released before attempting module removal.

Removal of 18" modules may require a second person to assist with support and lifting.

3. **18" Modules:** 18" modules are positioned in place with four dimples on the bottom surface. Remove passenger side countertop and release module clamps. Apply a slight upward force, along with a pulling force to nudge dimples free and slide module out. Ensure that it is adequately secured before completely removing from unit.

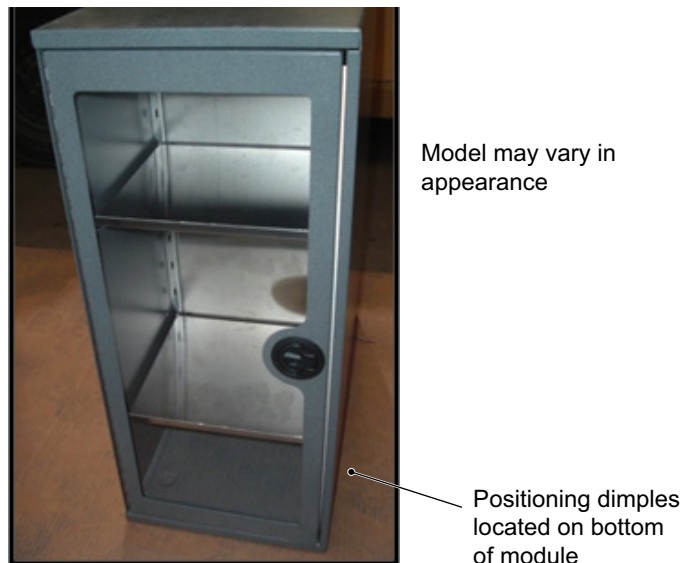

Read all of SAFETY and this section before attempting any procedure. Pay particular attention to Notices, Cautions, Warnings and Dangers.

Slide Out Compartments

1. **Hanger Board:** The pull out module has a hanger board inside that is equipped with slide rails to allow for cleaning and and/or refilling. The board inside can be removed after the slide locks are released.

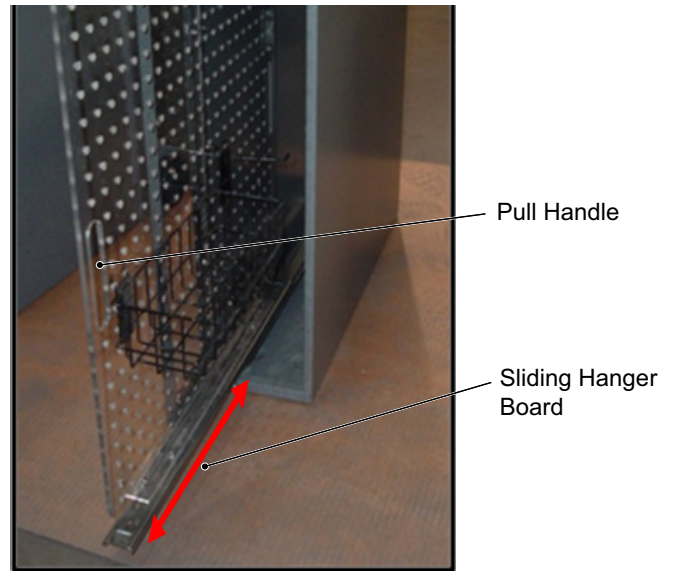

2. **Slide Out Trash Compartment:** The slide out trash compartment (located in the end cap) is equipped with a 10 lb. rated latch. A pulling force exceeding 10 lbs. is required to release the latch to allow the trash can housing to slide out of the unit.

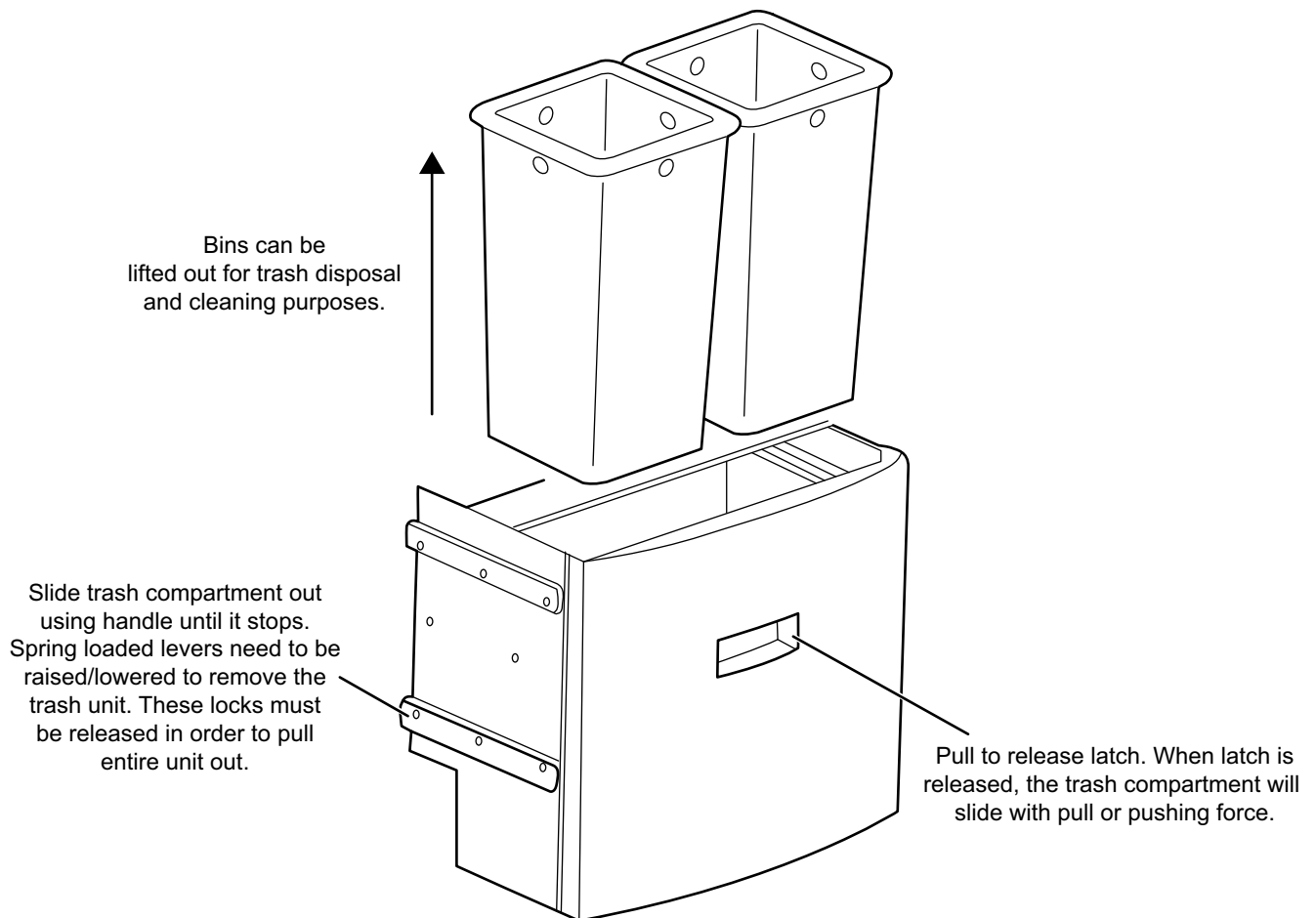

OPERATING PROCEDURES

Read all of SAFETY and this section before attempting any procedure. Pay particular attention to Notices, Cautions, Warnings and Dangers.

Removable Shelves and Inserts

1. Rear End Cap (above Trash Compartment)

- a. **Bottom Insert:** This insert has two functional sides; one side for beverage canisters and miscellaneous accessories, opposite side for various bottles/accessories. The insert can be pulled up and out of its position. Rotate to its opposite side and place back into position.

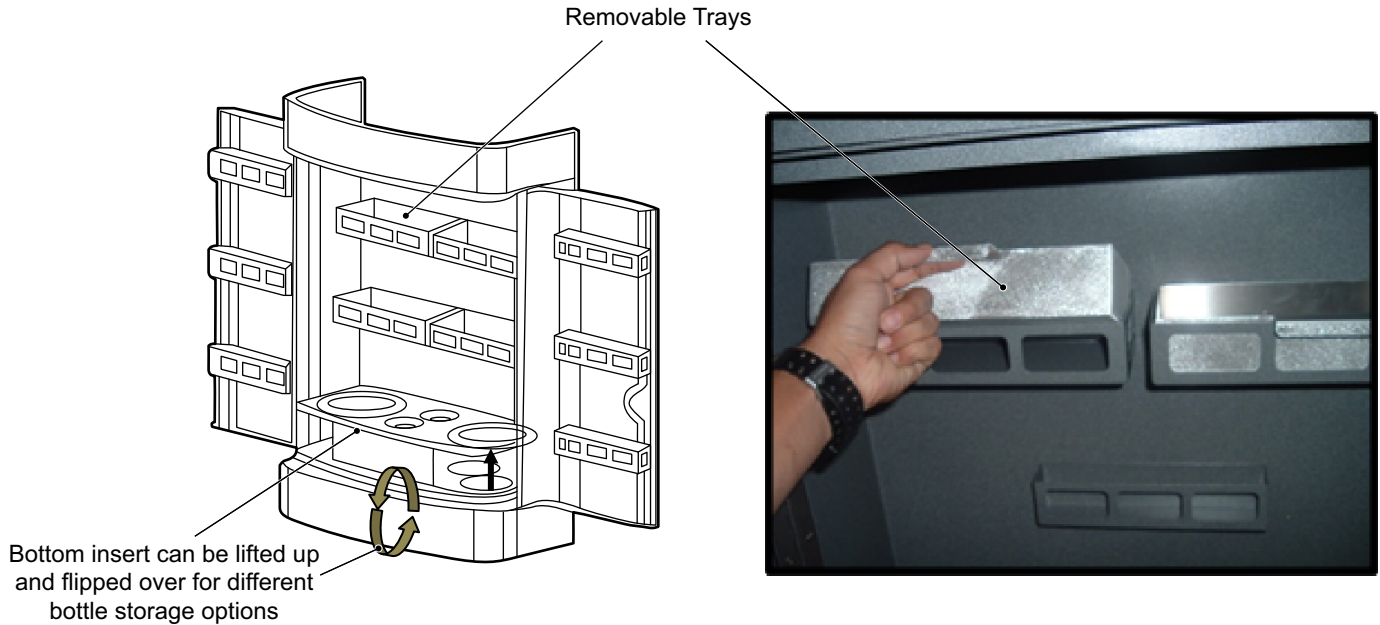

2. 12" and 18" Modules (unit may not be equipped with all modules)

- a. **12" and 18" Module with Shelves:** The shelves can be adjusted for custom compartment spacing or can be removed completely. 12" or 18" modules are equipped with two shelves.
- b. **18" Cup and Display Module:** This 18" module is equipped with two adjustable/removable shelves, one cup tray with four slots and one beverage box.

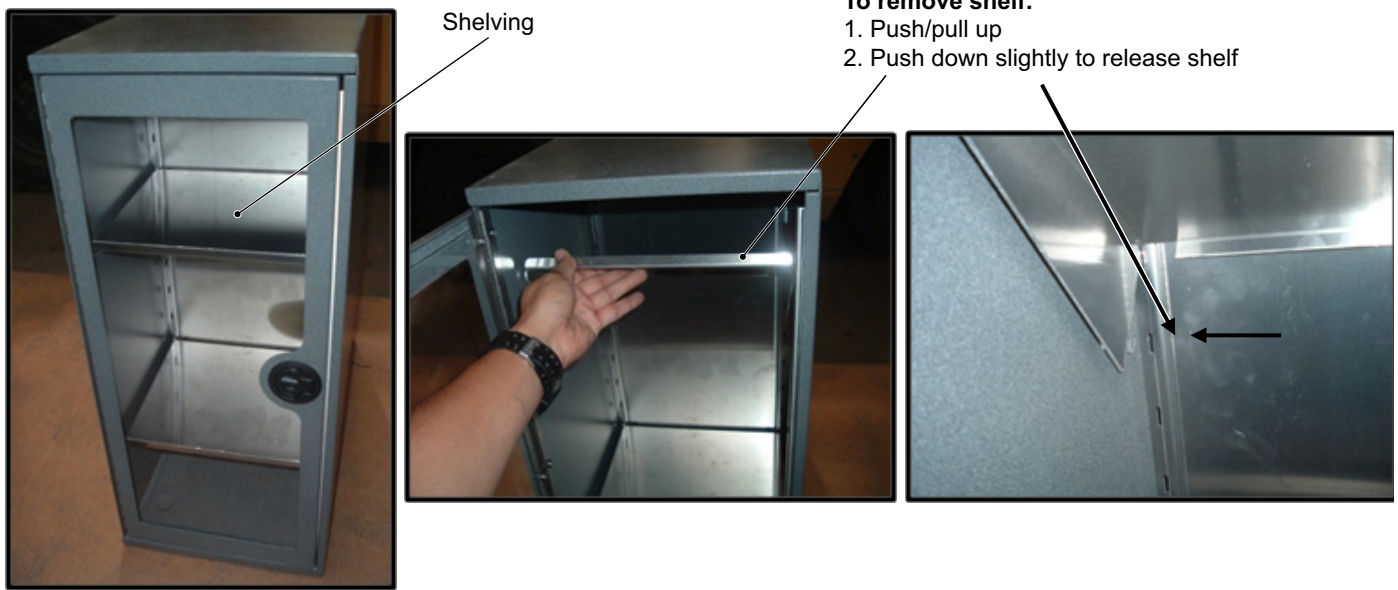

OPERATING PROCEDURES

Read all of SAFETY and this section before attempting any procedure. Pay particular attention to Notices, Cautions, Warnings and Dangers.

3. 6" and 12" Pull Out Modules (unit may not be equipped with all modules)

- a. **Hanger Inserts:** Hangers are located on the hanger board inside the 6" pull out module. The hangers can be placed in any position using holes provided on board.
- b. **Basket:** Two baskets are also provided with the hanger board. They can be placed in any position on the board or removed completely..



4. Side Drawers

- a. **Tray Insert:** An aluminum slide-able storage tray is located inside the side drawer.

To remove drawer from unit, pull drawer out, press down levers on each side to release pins and take entire drawer off slide rails.

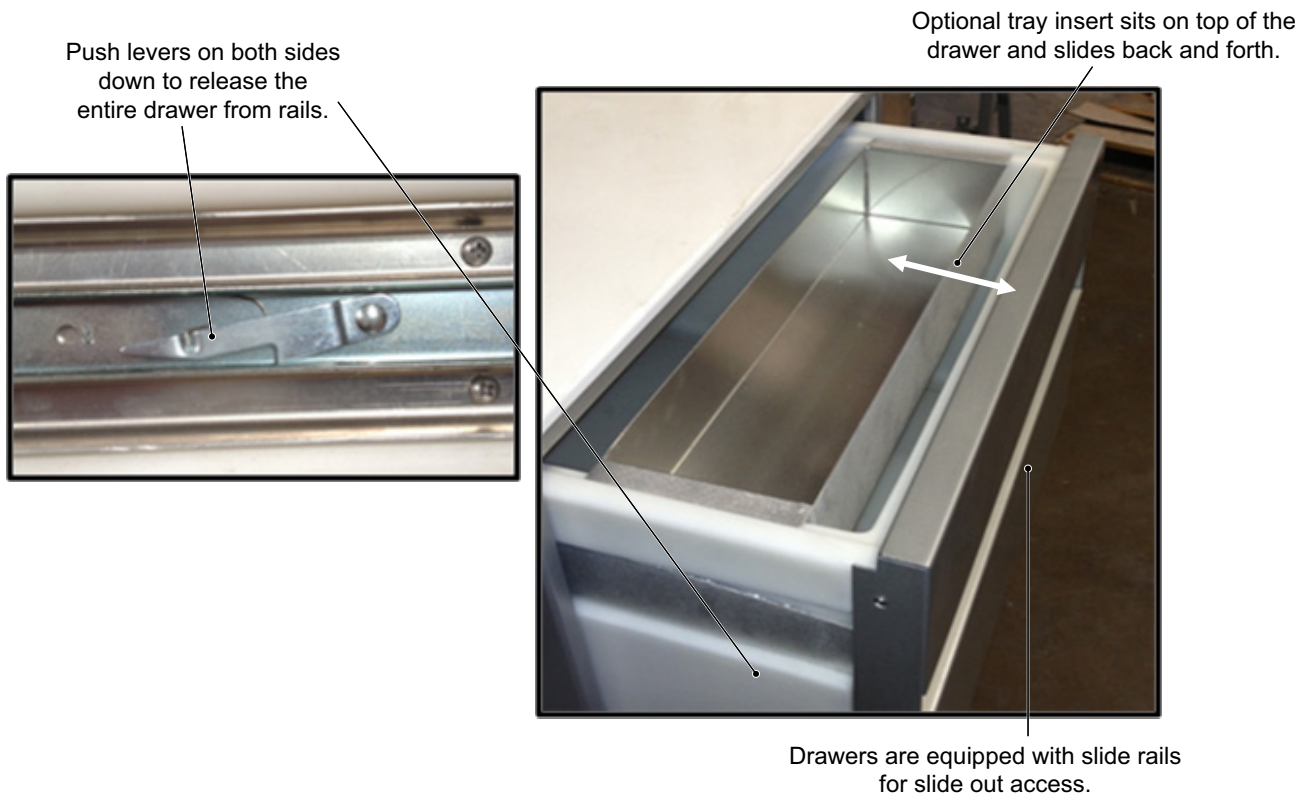

OPERATING PROCEDURES

Read all of SAFETY and this section before attempting any procedure. Pay particular attention to Notices, Cautions, Warnings and Dangers.

Compartment Storage

Unit may not be equipped with all modules described in this section.

1. **Rear End Cap (above Trash Can Compartment):** The door interiors can be used for mini bottles, snacks, chips etc. The main portion of the unit can be used for bottles, snacks, chips, napkins, etc. **Unopened, prepackaged non-perishable food only.**

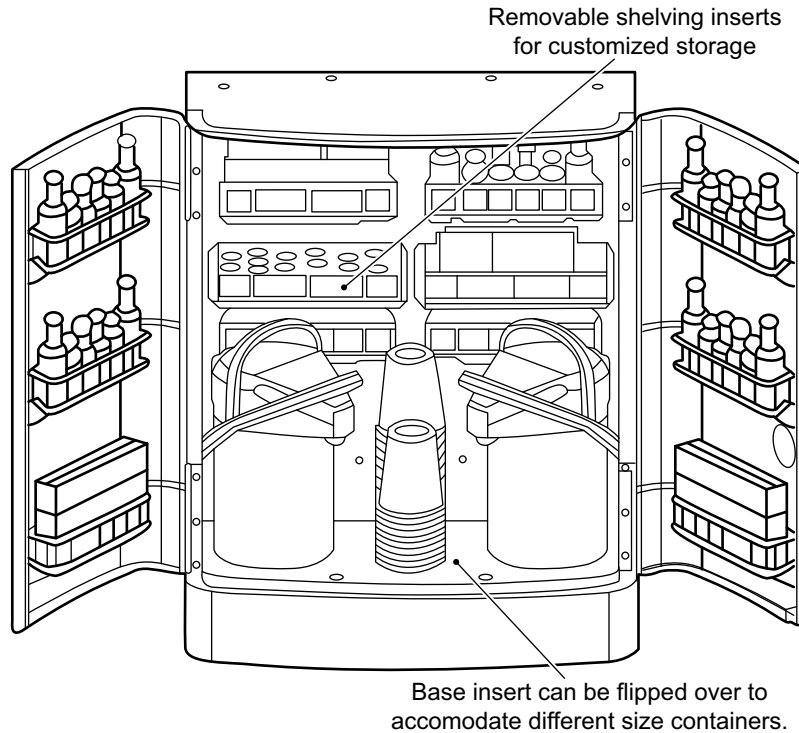

2. **Pull Out Module:** This module is designed to hold snacks, chips, etc. on the hanger board. Hanger inserts and baskets can be placed as desired to accommodate specific product layout. **Unopened, prepackaged non-perishable food only.**

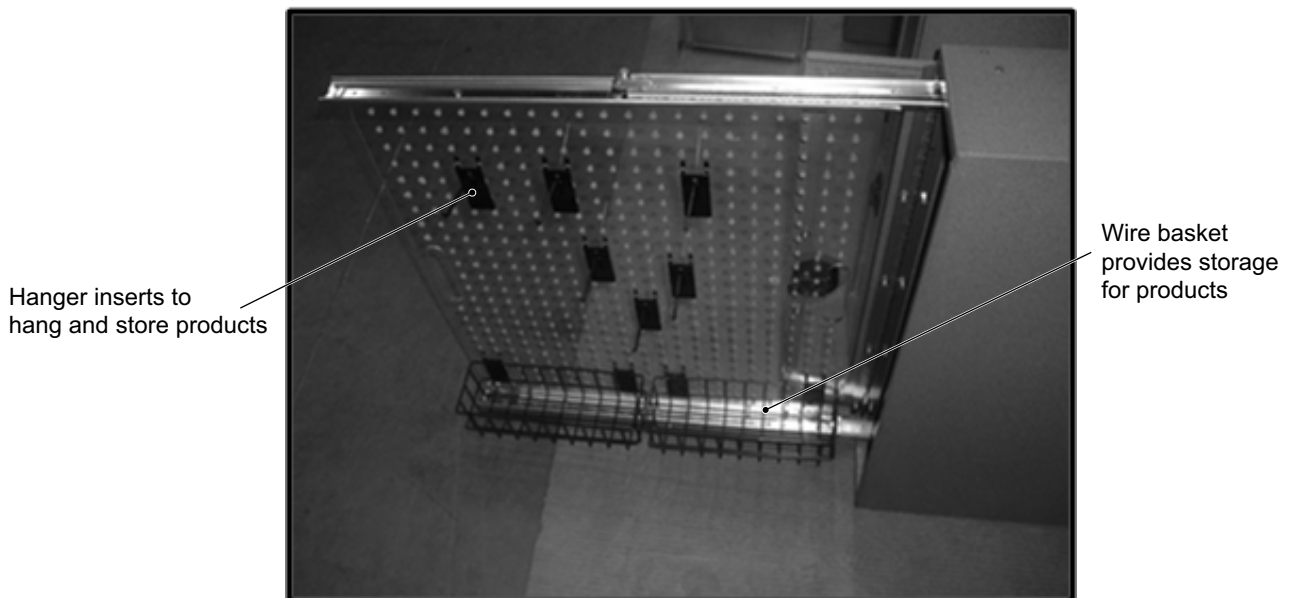

OPERATING PROCEDURES

Read all of SAFETY and this section before attempting any procedure. Pay particular attention to Notices, Cautions, Warnings and Dangers.

- 6" Cup Module:** This module has five cup racks and is designed for empty cup storage only. It is not intended for products requiring temperature cooling or heating. The cup racks are removable for refilling and cleaning purposes.

This module is recommended for empty cup storage only.

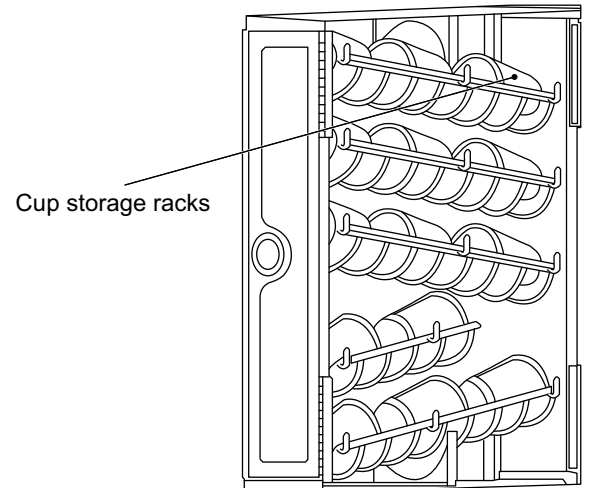

- 12" and 18" Modules with Shelves:** These modules can be used for various storage options to accommodate needs or service. Modules are not temperature regulated or insulated and are not designed for cooling and/or heating of any products or food. **Unopened, prepackaged non-perishable food only.**

- 18" Cup and Display Module (not pictured):** This module is similar to the 18" module with shelves with the difference being narrower shelves and an added cup rack feature.

Module provides two adjustable shelves for various storage options and racks for empty cup storage. Modules are not temperature regulated or insulated and are not designed for cooling and/or heating of any products or food. **Unopened, prepackaged non-perishable food only.**

Two adjustable/removable shelves



- Rear Corner Compartment (at each corner of end cap):** Two corner compartments provide storage options for miscellaneous product needs. Compartments are not temperature regulated or insulated, so products needing to be cooled and/or heated should not be stored here. Dry food and beverage products are also not recommended for this area. **Unopened, prepackaged non-perishable food only.**



OPERATING PROCEDURES

Read all of SAFETY and this section before attempting any procedure. Pay particular attention to Notices, Cautions, Warnings and Dangers.

7. **Side Drawers:** The side drawers are designed for cold product storage, such as ice and beverages. Each drawer has a drain for emptying and cleaning purposes.

An optional, removable, sliding tray is available for additional storage requirements.

Unopened, prepackaged non-perishable food only.

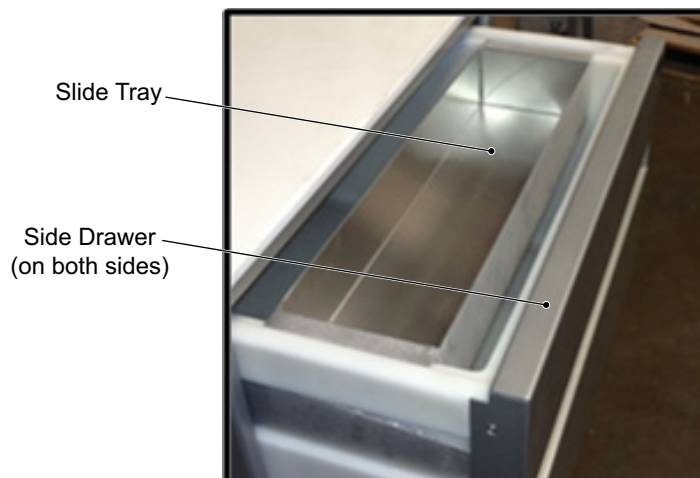

Drawer Operation

To open side drawer, use two hands in the open palm position with finger tips under the bar. Apply force by pulling up with fingers and the slide out the drawer to the distance needed. The bar lever is spring loaded and upon release, locks the drawer from moving.



Pull up and out with BOTH HANDS.

Read all of SAFETY and this section before attempting any procedure. Pay particular attention to Notices, Cautions, Warnings and Dangers.

Trash Compartment Operation

The trash compartment is equipped with slide rails on each side for pull out access. Inside the pull out compartment are two removable trash bins. Remove trash bins from compartment to empty and/or clean.

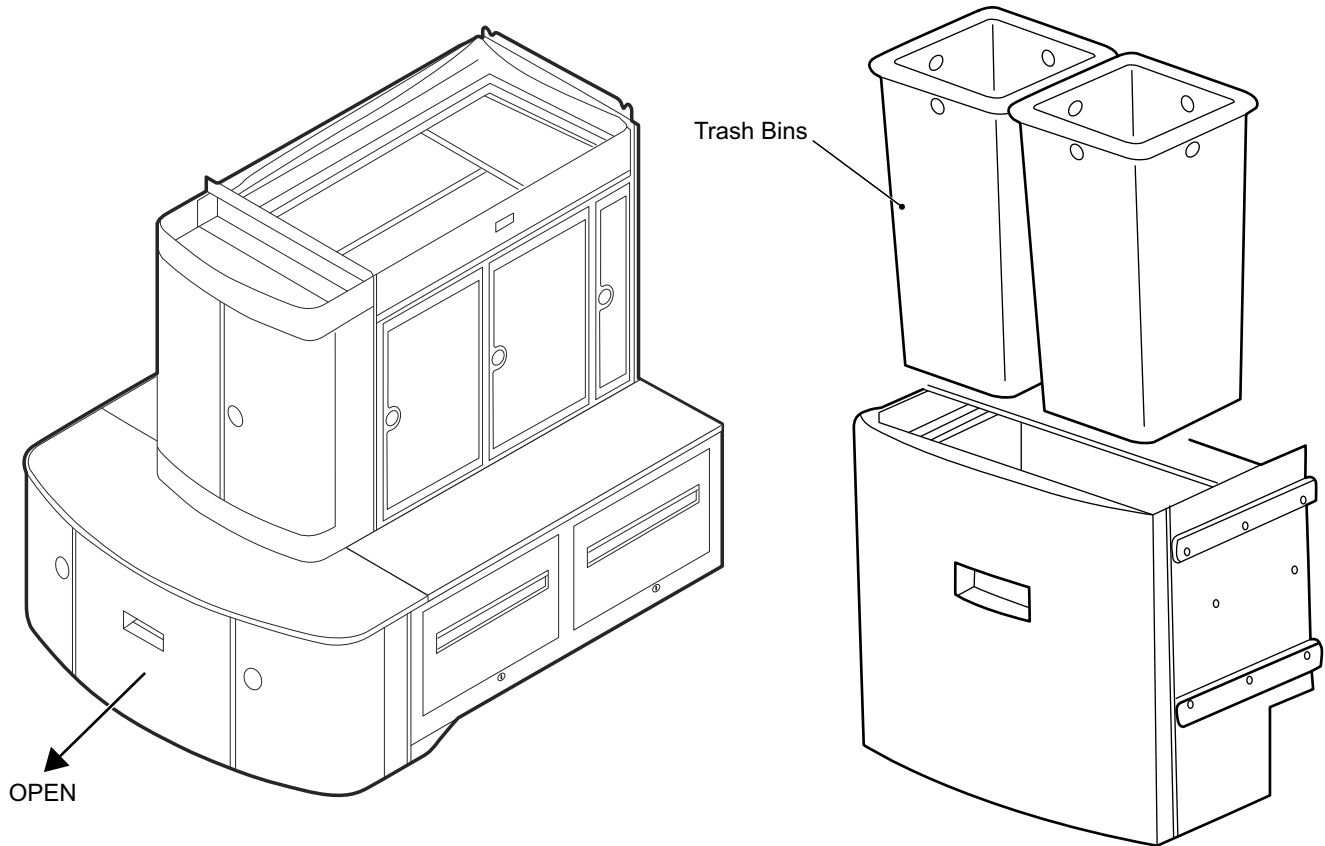

Keys and Locks

Two different keys are provided with the unit; one for door locks and one for drawer locks. All doors and drawers are lockable except the trash compartment.

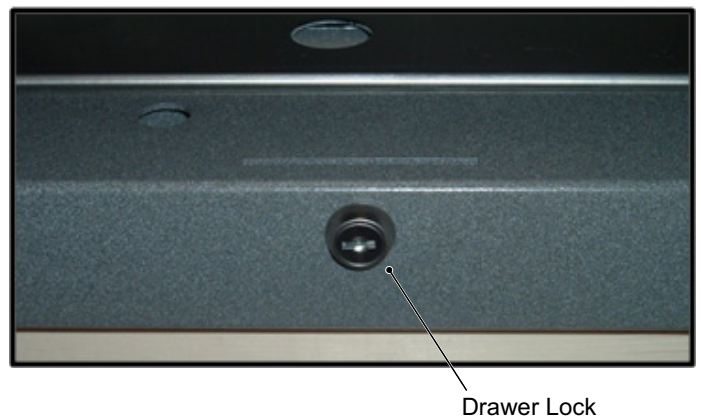

Cleaning the Refresher Unit

Refresher unit should be maintained and cleaned after each use.

- **Side Drawers:** Side drawers should be maintained and cleaned after use. Commercial safe detergent is recommended.
- **Trash Compartment:** The trash bins should be emptied as necessary and cleaned after each use. The entire trash compartment should be cleaned after each use. Commercial safe detergent is recommended.
- **All Other:** Clean all used areas of Refresher unit with commercial safe detergent.

OPERATING PROCEDURES

Read all of **SAFETY** and this section before attempting any procedure. Pay particular attention to **Notices, Cautions, Warnings and Dangers.**

CHANGING THE CANOPY

Remove canopy before trailering or shipping vehicle.

1. Open the Velcro closures on all sides of canopy to release it from the frame.



Canopy tubing support

2. Remove canopy top from frame.
3. To reattach canopy, start with one end and cover corners around the frame.
4. Pull all edges of canopy tight and secure with Velcro.

Read all of SAFETY and this section before attempting any procedure. Pay particular attention to Notices, Cautions, Warnings and Dangers.

Notes:

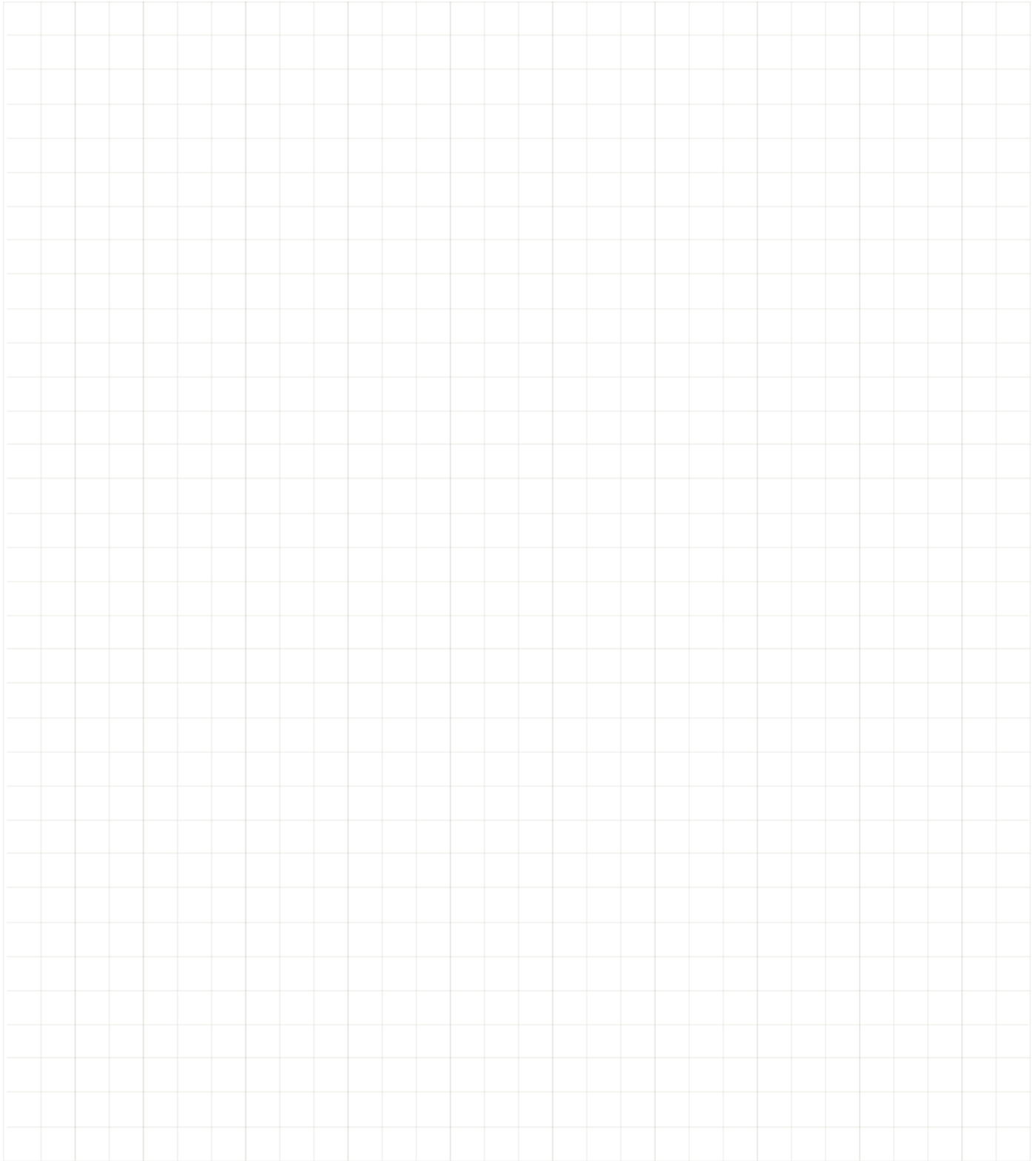
A large grid of graph paper for taking notes, consisting of 20 columns and 30 rows of small squares.

OPERATING PROCEDURES

Read all of SAFETY and this section before attempting any procedure. Pay particular attention to Notices, Cautions, Warnings and Dangers.

Notes:

A large grid of graph paper for taking notes, consisting of 20 columns and 30 rows of small squares.

Read all of SAFETY and this section before attempting any procedure. Pay particular attention to Notices, Cautions, Warnings and Dangers.

MAINTENANCE

VEHICLE CLEANING AND CARE

Vehicle Cleaning

WARNING

To reduce the possibility of severe injury or vehicle damage, read and understand all instructions supplied by manufacturer of pressure washer prior to use.

CAUTION

Do not exceed 700 psi when pressure washing exterior of vehicle.

Using abrasive or reactive solvents for cleaning plastic parts may result in cosmetic damage.

It is important that proper techniques and cleaning materials to be used. Using excessive water pressure may cause severe injury to operator or bystander, damage to seals, plastics, seat material, body finish or electrical system. Do not use pressure exceeding 700 psi on exterior of vehicle.

Clean windshield with water and a clean cloth. Minor scratches may be removed using a commercial plastic polish or Plexus® plastic cleaner available from the service parts department.

Normal cleaning of vinyl seats and plastic or rubber trim can be done with a mild soap solution applied with a sponge or soft brush and wiped with a damp cloth.

Oil, tar, asphalt, shoe polish, etc. can be removed with commercially available vinyl/rubber cleaner.

The painted surfaces of the vehicle provide attractive appearance and durable protection. Frequent washing with luke-warm or cold water and mild detergent is required to preserve the painted surfaces.

Occasional cleaning and waxing with non-abrasive products designed for 'clear coat' automotive finishes will enhance the appearance and durability of the painted surfaces.

Corrosive materials used as fertilizers or for dust control can collect on the underbody of the vehicle. These materials will cause corrosion of underbody parts unless flushed occasionally with plain water. Thoroughly clean any areas where mud or other debris can collect. Sediment packed in closed areas should be loosened to ease removal, taking care not to chip or otherwise damage paint.

NOTICE

If the engine does not start or runs improperly after washing, remove the spark plug wires (by pulling the spark plug boots, not the wires). Dry all connections with forced air. Reinstall wires.

Refresher Unit Cleaning

Regular cleaning is required to obtain optimum use of the FS4 Refresher unit. Remove all merchandise and product prior to cleaning. Clean countertops, module units, side drawers, end cap, and trash compartment with commercial cleaners. A standard all-purpose antibacterial cleaner is sufficient for most of the surfaces. Ensure all surfaces are dried and free of cleaner residue. Drawers and drawer drains must be cleaned and dried after each use.

MAINTENANCE

Read all of SAFETY and this section before attempting any procedure. Pay particular attention to Notices, Cautions, Warnings and Dangers.

COMMON SENSE OPERATION

THIS VEHICLE IS NOT A TOY. If not operated properly and responsibly, it can cause severe injury or death to the operator, passengers or bystanders. All operators should possess a valid drivers license. Children should not be permitted to operate the vehicle since they may not have the skill, judgment or strength to operate this or similar vehicles.

Alcohol, drugs and many over the counter medications reduce the ability of the driver to operate the vehicle safely. Always review side effects of any medication with a doctor or pharmacist before operating vehicle.

When driving at full speed on dirt road, loose surface or wet grass, the distance required to stop vehicle will increase. If the vehicle is fully loaded, it will require more distance to stop than with no load. When operating vehicle in wet weather conditions, remember that the brakes may need to be **lightly** applied in order to provide enough friction to dry the brake unit. Wet brakes lose much of their effect.

Slow down when in unfamiliar terrain. Slow down when cresting a hill in an unfamiliar area.

Some hills are too steep to climb. If attempting to climb a hill that is too steep or if unable to achieve adequate traction, **do not attempt to turn around on the hill. Slowly back straight down the hill using the service brake to control speed.**

ENVIRONMENTAL CONCERNS

WARNING

Respect all wildlife and their habitat.

Respect private property and comply with local laws and regulations governing the use of light duty utility vehicles.

To prevent severe injury or death while driving, be aware of the following:

Environmental hazards such as steep slopes, overhanging limbs, etc.

Danger of fire when vehicle is operated over dry combustible organic material.

When operating vehicle, be aware of environmental hazards such as steep slopes, overhanging limbs, etc. Be aware of the danger of fire when the gasoline powered vehicle is driven over dry combustible organic material.

REPAIR

Some servicing operations may require the front wheels, the rear wheels, or the entire vehicle to be raised.

WARNING

To reduce the possibility of severe injury or death from a vehicle falling from a jack:

Use caution since the vehicle is extremely unstable during the lifting process.

Be sure the vehicle is on a firm and level surface for the lifting process.

Never get under a vehicle while it is supported by a jack only.

Use jack stands and test stability of the vehicle on stands prior to getting underneath.

Place chocks in front and behind wheels not being raised.

Read all of SAFETY and this section before attempting any procedure. Pay particular attention to Notices, Cautions, Warnings and Dangers.

CAUTION

When lifting vehicle, position the jacks and jack stands only at the areas indicated in illustration.

Lifting the Vehicle

Tool List	Qty.	Tool List	Qty.
Floor Jack.....	1	Jack Stands.....	4
Wheel Chocks	4		

Remove load from vehicle before lifting. No person(s) should be in or on the vehicle while lifting.

To raise the entire vehicle:

1. Install chocks in front and behind each front wheel.
2. Center the jack under the rear frame crossmember.
3. Raise the vehicle enough to place a jack stand under the outer ends of the rear axle as shown in illustration.
4. Lower the jack and test the stability of the vehicle on the two jack stands.
5. Place the jack at the center of the front axle.
6. Raise the vehicle enough to place jack stands under the frame crossmember as shown in illustration.
7. Lower the jack and test the stability of the vehicle on all four jack stands.

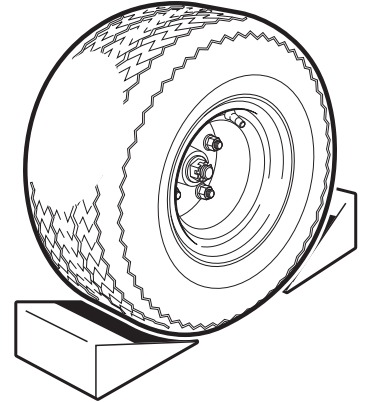

If only one end of the vehicle needs to be raised, place chocks in front and behind each wheel not being raised to stabilize the vehicle.

Lower the vehicle by reversing the lifting sequence.

View from Underside of Vehicle

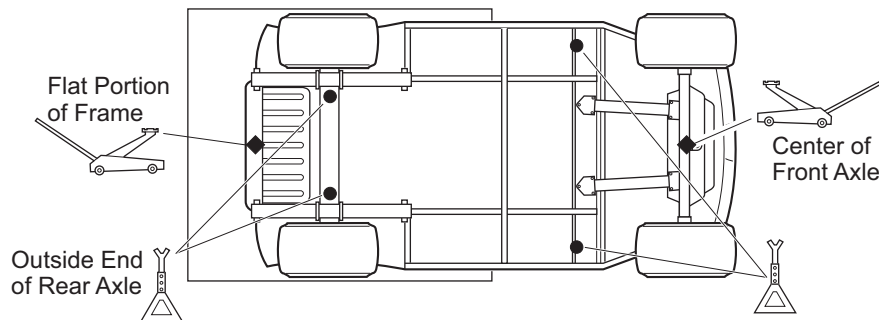

WHEELS AND TIRES

WARNING

A tire explosion can cause severe injury or death. Do not exceed the inflation pressure rating on the tire sidewall.

To reduce the possibility of tire explosion, pressurize tire with small amounts of air applied intermittently to seat beads. Due to the low volume of the small tires, over-inflation can occur in sec-

MAINTENANCE

Read all of SAFETY and this section before attempting any procedure. Pay particular attention to Notices, Cautions, Warnings and Dangers.

onds. Do not exceed the tire manufacturer's recommendation when seating a bead. Protect face and eyes from escaping air when removing a valve core.

To reduce the possibility of severe injury caused by a broken socket when removing wheels, use only sockets designed for impact wrench use.

DO NOT use low inflation tires on a Cushman vehicle. DO NOT use any tire which has a recommended inflation pressure less than 45 - 55 psi (310 - 379 kPa).

Use caution when inflating tires. Over-inflation could cause the tire to separate from the wheel or cause the tire to explode, either of which could cause severe injury.

Tire Repair

Tool List	Qty.	Tool List	Qty.
Lug Wrench, 3/4"	1	Impact Socket, 3/4"	1
Impact Wrench	1	Torque Wrench	1

Use caution when inflating tires. Due to the low volume of the small tires, over-inflation can occur in seconds. Over inflation could cause the tire to separate from the wheel or cause the tire to explode.

The recommended tire inflation pressure is 45 - 55 psi (310 - 379 kPa). Tire inflation should be determined by the condition of the terrain.

For outdoor applications with major use on grassy areas, the following should be considered:

- On hard turf, it is desirable to have a **slightly** higher inflation pressure.
- On very soft turf, a lower pressure reduces the possibility of tires cutting into the turf.
- For vehicles being used on paved or hard surfaces, tire inflation pressure should be in the higher allowable range, but under no condition should inflation pressure be higher than recommended on tire sidewall.

All four tires should have the same pressure for optimum handling characteristics. Be sure to install the valve stem dust cap after checking or inflating.

The vehicle is fitted with low pressure tubeless tires mounted on one piece rims; therefore, the most cost effective way to repair a puncture in the tread is to use a commercial tire plug.

NOTICE

Tire plug tools and plugs are available at most automotive parts outlets and have the advantage of not requiring the tire be removed from the wheel.

If the tire is flat, remove the wheel and inflate the tire to the maximum recommended pressure for the tire. Immerse the tire in water to locate the leak and mark with chalk. Insert tire plug in accordance with manufacturer's instructions.

WARNING

To reduce the possibility of severe injury, be sure the mounting/demounting machine is anchored to floor. Wear OSHA approved safety equipment when mounting/demounting tires.

If the tire is to be removed or mounted, the tire changing machine manufacturer's recommendations must be followed in order to reduce possibility of severe injury.

Read all of SAFETY and this section before attempting any procedure. Pay particular attention to Notices, Cautions, Warnings and Dangers.

Wheel Installation

⚠ CAUTION

To reduce the possibility of component damage, do not tighten lug nuts to more than 100 ft. lbs. (136 Nm) torque.

NOTICE

It is important to follow the 'cross sequence' pattern when installing lug nuts to ensure even seating of the wheel against the hub.

With the valve stem to the outside, mount the wheel onto the hub with lug nuts (1). Finger tighten the lug nuts and tighten lug nuts in a 'cross sequence' pattern as shown, to a torque of 40 - 60 ft. lbs. (54 - 81 Nm). Finally, tighten the lug nuts to torque of 80 - 100 ft. lbs. (108 - 136 Nm).

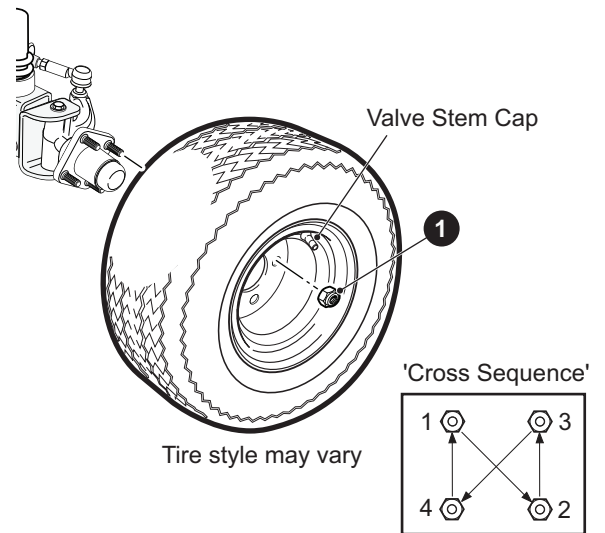

LIGHT BULB REPLACEMENT

⚠ CAUTION

To reduce possibility of premature bulb failure, do not touch new bulbs with bare fingers. Use clean, dry tissue or paper towel to handle the glass portion of bulb.

Locate bulb socket on backside of headlight housing and turn bulb socket a quarter turn counterclockwise to unlock and pull out bulb and socket. Insert new bulb and rotate socket a quarter turn clockwise to secure.

To replace the turn signal bulb, locate bulb socket on backside of headlight housing and turn bulb socket a quarter turn counterclockwise to unlock and pull out bulb and socket. Insert new bulb and rotate socket a quarter turn clockwise to secure.

To replace the taillight bulb, roll the rubber bezel from around the edge of the taillight and remove lens. Install replacement bulb and replace lens.

Light bulbs are available from a local distributor, an authorized branch or the service parts department.

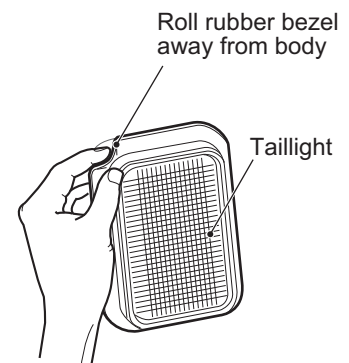
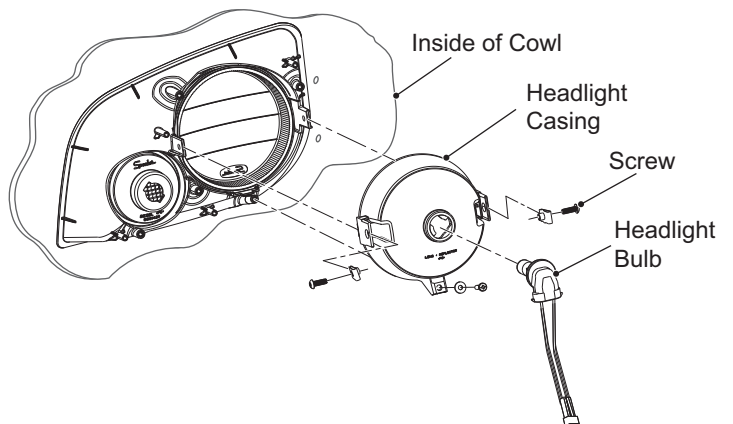

FUSE REPLACEMENT

Locate the fuse block under the drivers seat. Pull out old fuse and replace with a new automotive type fuse. Fuses are available from a local distributor, an authorized branch or the service parts department.

MAINTENANCE

Read all of SAFETY and this section before attempting any procedure. Pay particular attention to Notices, Cautions, Warnings and Dangers.

VEHICLE WITH A DISCHARGED BATTERY

WARNING

To reduce the possibility of severe injury or death from inadvertent motion, do not attempt to 'jump start' a vehicle.

The vehicle is equipped with a starter/generator and does not idle. When starting the engine, the starter/generator functions as a starter and with the engine running, it functions as a generator.

With the short running times associated with this kind of vehicle, the generator is more than adequate to maintain the battery charge level. The generator is not designed to charge a discharged battery.

When the engine starts, the clutches engage and cause the vehicle to move making 'jump starting' both dangerous and impractical.

If the vehicle battery has become discharged, it can be charged using a 12 volt charger that is rated at 10 amps or less. Read and understand all instructions provided by the manufacturer of the charger.

TRANSPORTING VEHICLE

WARNING

This vehicle is not designed to be towed.

Do not tow this vehicle. The vehicle should be moved by placing the entire vehicle on a trailer, flatbed truck or other suitable transport.

Neutral Lock

A neutral lock is located on the direction selector to prevent the driven clutch from turning the rear wheels during service operations.

To operate neutral lock:

1. Turn key switch to 'OFF' and lift seat bottom.
2. Pull out (1) and rotate (2) the neutral lock pin handle so that the pointed portion of the handle is to the side of the direction selector cam.
3. Move direction selector towards the area between 'F' and 'R'. During that motion the pin will snap into the hole in the direction selector mounting bracket preventing any movement. When in this position, the direction selector remains locked in the neutral position.
4. To unlock the direction selector, pull the neutral lock pin handle out and rotate until the pointed portion of the handle fits into the hole in the direction selector cam.

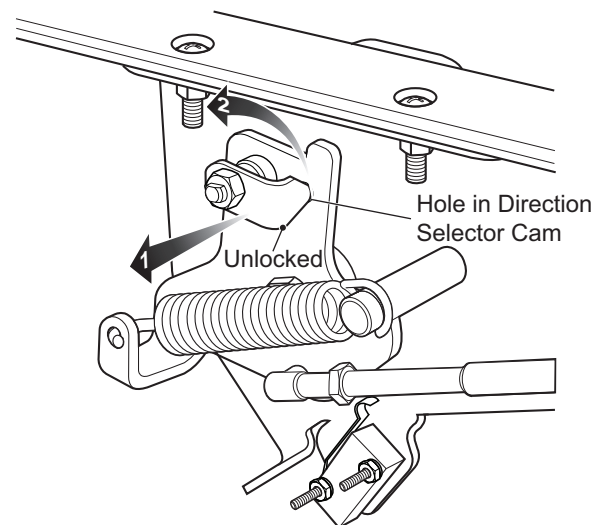

Read all of SAFETY and this section before attempting any procedure. Pay particular attention to Notices, Cautions, Warnings and Dangers.

⚠ WARNING

To reduce the possibility of severe injury or death while transporting the vehicle:

- Secure the vehicle and contents.
- Do not ride on a vehicle being transported.
- Remove windshield before transporting.
- Remove the removable countertop section.
- Ensure unit drawers and module doors are locked.
- Ensure unit is empty to avoid weight shifting.
- Remove canopy if transporting at highway speeds.

If vehicle is to be transported at highway speeds, the canopy and removable countertop must be removed and the seat bottom secured. When transporting vehicle below highway speeds, check for tightness of hardware and cracks in canopy at mounting points. Always remove windshield when transporting. Always check that the vehicle and contents are adequately secured before transporting. The rated capacity of the trailer or truck must exceed the weight of the vehicle (see GENERAL SPECIFICATIONS for vehicle weight) and load plus 1000 lbs. (454 kg). Secure the vehicle using ratchet tie downs.

SERVICE AND MAINTENANCE

⚠ WARNING

To reduce the possibility of severe injury or death from improper servicing techniques:

DO NOT attempt any type of servicing operations before reading all notices, cautions and warnings in this manual.

Any servicing requiring adjustments to be made to the powertrain while the engine is running must be made with both drive wheels raised and vehicle properly supported on jack stands.

To reduce the possibility of engine damage, never operate vehicle at full throttle for more than 4 - 5 seconds while vehicle is in a 'no load' condition.

Reduce the possibility of accidental starting by disconnecting battery at negative terminal before servicing.

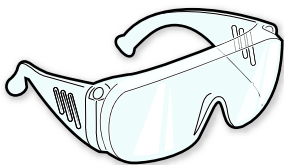

Wear eye protection when working on the vehicle. Use extra care when working around batteries, or using solvents or compressed air.

To reduce the possibility of causing an electrical arc, which could result in a battery explosion, turn off all electrical loads from the battery before removing battery wires.

MAINTENANCE

Read all of SAFETY and this section before attempting any procedure. Pay particular attention to Notices, Cautions, Warnings and Dangers.



Wrap wrenches with vinyl tape to reduce possibility of a dropped wrench 'shorting out' a battery, which could result in an explosion.

The electrolyte in a battery is an acid solution which can cause severe burns to the skin and eyes. Treat all electrolyte spills to the body and eyes with extended flushing with clear water. Contact a physician immediately.

Any electrolyte spills should be neutralized with a solution of 2 teaspoons (10 ml) sodium bicarbonate (baking soda) dissolved in 1 quart (1 liters) of water and flushed with water.

Aerosol containers of battery terminal protectant must be used with extreme care. Insulate metal container to reduce the possibility of can contacting battery terminals which could result in an explosion.

It is in the best interest of both vehicle owner and service technician to carefully follow the procedures recommended in this manual. Preventative maintenance, applied at recommended intervals, is the best guarantee for keeping the vehicle both dependable and economical.

This vehicle will give years of satisfactory service, providing it receives regular maintenance. Refer to the Periodic Service Schedule for appropriate service intervals.

ROUTINE MAINTENANCE



To prolong vehicle life, some maintenance items must be serviced more frequently on vehicles used under severe driving conditions such as extreme temperatures, extreme dust/debris conditions, or frequent use with maximum load.

For information on accessing the powertrain for routine maintenance, refer to "Emissions Labels and Engine Access" on page 25.

Some service procedures may require the vehicle to be lifted. Refer to "Lifting the Vehicle" on page 41 for proper lifting procedure and safety information.

Tire Inspection

Tire condition should be inspected per the Periodic Service Schedule. Inflation pressures should be checked when the tires are cool. Be sure to install the valve dust cap after checking or inflating.

Rear Axle

The only maintenance required for the first five years is the periodic inspection of the rear axle for lubricant leakage. Unless leakage is evident, the lubricant need only be replaced after five years. Refer to the Service and Repair Manual for the fluid replacement procedure.

FOUR CYCLE ENGINE

Engine Specifications

Engine Model	FJ400D	Spark Plug Type	NGK BPR2ES
Type.....	Four Cycle, OHV	Spark Plug Gap.....	.028" - .031" (.70 - .80 mm)
Number of Cylinders.....	1	Cooling	Forced Air Cooled
Displacement.....	401 cc	Oil Filter.....	Cartridge Type Full Flow
Rated Horsepower	13 hp	Oil Pump	Positive Displacement

Read all of SAFETY and this section before attempting any procedure. Pay particular attention to Notices, Cautions, Warnings and Dangers.

Engine Description

The engine is an air cooled, 4-stroke, OHV, single cylinder gasoline engine. It incorporates a pressure fed lubrication positive displacement oil pump with a cartridge type full flow oil filter and a counter rotating balance shaft.

Checking the Oil Level

CAUTION

Do not overfill engine. Too much oil may cause engine to smoke or cause spark plug fouling.

Do not overfill engine. Too much oil may cause smoking or allow oil to enter the air filter enclosure.

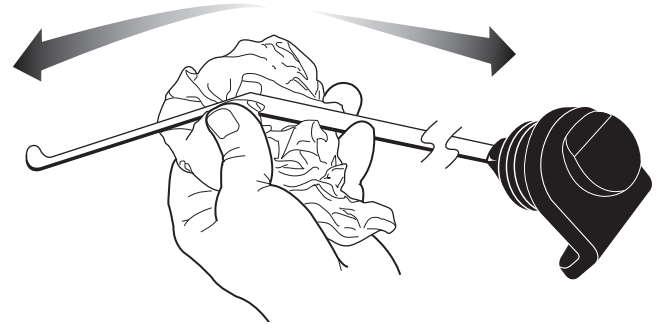

The oil should be checked with the engine warm and vehicle parked on a level surface with the parking brake engaged. Allow oil to drain into crankcase before checking.

Remove the dipstick and wipe off the entire area with a lint free cloth.

Insert the dipstick **fully** into the dipstick hole and then remove it. Examine the level of the oil on the dipstick.

The engine can be operated safely as long as oil is within the safe operating range as indicated on the dip stick. **Do not operate vehicle if oil level is below the safe area indicated on the dipstick.**

Oil should be added to bring the level into the safe operating range. Remember that oil expands as it gets hot, **Do not overfill**. Check that the oil cap is firmly in place.

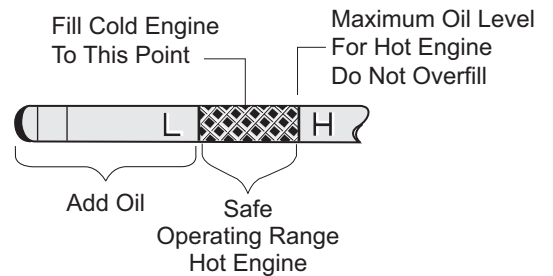

NOTICE

The oil dipstick/fill cap must be in place before operating the engine. Failure to install the dipstick/fill cap will result in oil becoming contaminated and/or oil being discharged into the engine compartment.

Changing the Oil

Tool List	Qty.	Tool List	Qty.
Socket, 19 mm	1	Oil Filter Wrench	1
Ratchet	1	Oil Drain Pan.....	1
Extension, 8"	1		

MAINTENANCE

Read all of SAFETY and this section before attempting any procedure. Pay particular attention to Notices, Cautions, Warnings and Dangers.

For maximum performance and longevity, the engine oil should be replaced after the first eight hours of operation. After the initial oil change, it should be changed every 125 hours of operation or semi-annually, whichever comes first.

The selection of oil is dependent upon the service that the vehicle will perform. Most vehicles require 10W-30 oil, whereas vehicles used at capacity or near capacity load applications will utilize 10W-40 oil after a break-in period of 100 hours.

NOTICE

If vehicle is to be stored over winter months, it can be stored with old oil left in engine. The oil should be changed as part of spring maintenance to remove any moisture that has accumulated during storage.

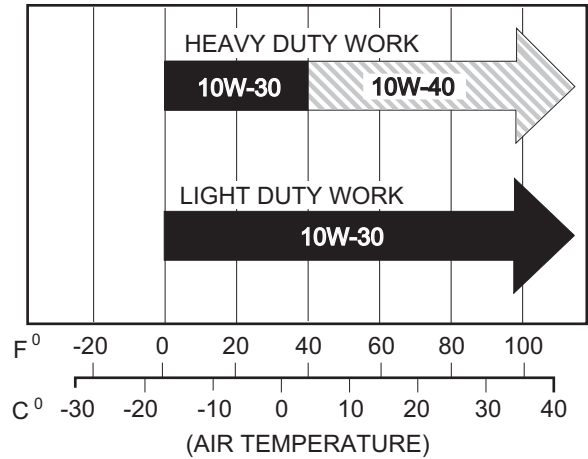

WARNING

Be aware that engine fluids may be hot and contact to the skin may cause severe burns. Wear rubber gloves to protect skin from exposure to the old oil and degreaser.

The oil should be changed with engine warm. Park vehicle on a level surface, engage parking brake and remove key.

Place a drain pan under engine. Wipe top of the engine clean with a cloth. Remove the oil fill cap.

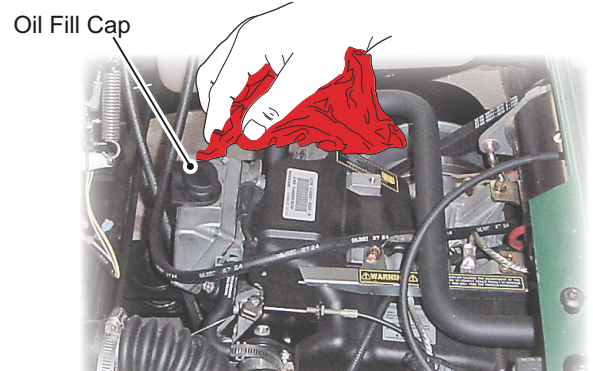

WARNING

Be careful of hot oil when drained. It may be hot enough to burn you severely

Place the oil drain pan under the oil drain plug (1) found at the rear of the engine base.

Remove the drain plug (1) and allow the oil to drain into the pan. At the first oil change, **small** metal chips and lint may be found. This is normal, resulting from the break-in period. Inspect the filter at every oil change. The presence of large metal chips could indicate possible damage to the engine. Before installing the drain plug, clean the area around the drain hole with a lint free cloth and inspect the drain plug (1) for damage; replace if necessary. If the O-ring (2) on the drain plug is damaged replace it with a new one. Tighten the drain plug to 62 in. lbs (7 Nm) torque.

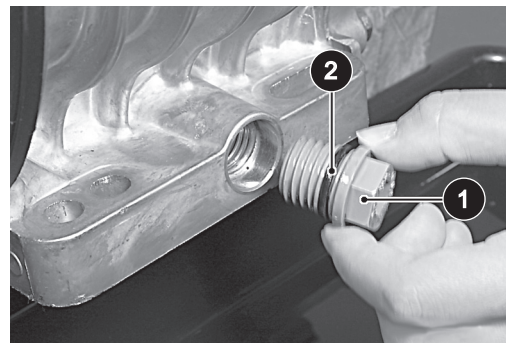

Read all of SAFETY and this section before attempting any procedure. Pay particular attention to Notices, Cautions, Warnings and Dangers.

Clean the area around filter. Use a filter wrench (3) to remove the filter (4) from the engine and allow the oil to drain.

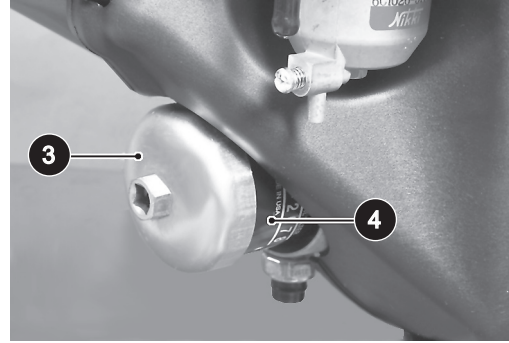

The O-ring (5) may have remained on engine (6) or filter (7). If the O-ring (5) remained on the engine surface (6), remove it and discard with the filter (7).

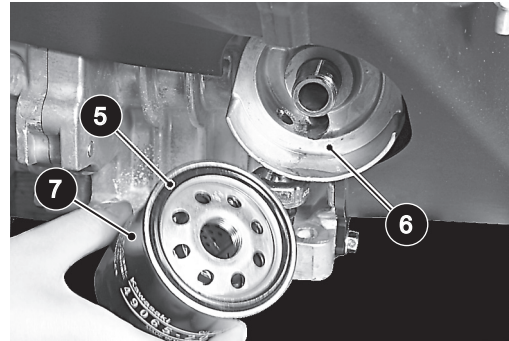

Inspect the new oil filter for any defects, apply engine oil to the oil filter O-ring (5) and install oil filter onto the engine until the seal contacts mounting surface of the engine. Then turn the filter 2/3 to 3/4 rotations by HAND(S). Pour in the specified type and amount of oil. See “CAPACITIES AND REPLACEMENT PARTS” on page 56.

Oil capacity is 1-1/3 quarts (1.3 liters). Add slightly less than 1-1/3 quarts (1.3 liters) to allow for possible residual oil left in engine. The oil must be high quality oil that meets or exceeds API SF, SG, CC standards. Check oil level on dipstick. Oil should be slightly below ‘H’ to allow for expansion. If necessary, continue to add oil slowly and allow time for oil to flow down into engine. Check oil level on dipstick. **Do not overfill.**

CAUTION

Do not overfill engine. Too much oil may cause smoking or allow oil to enter the air filter enclosure.

NOTICE

Both the oil dipstick and fill cap must be in place before operating the engine. Failure to install the dipstick and fill cap will result in oil being discharged into the engine compartment

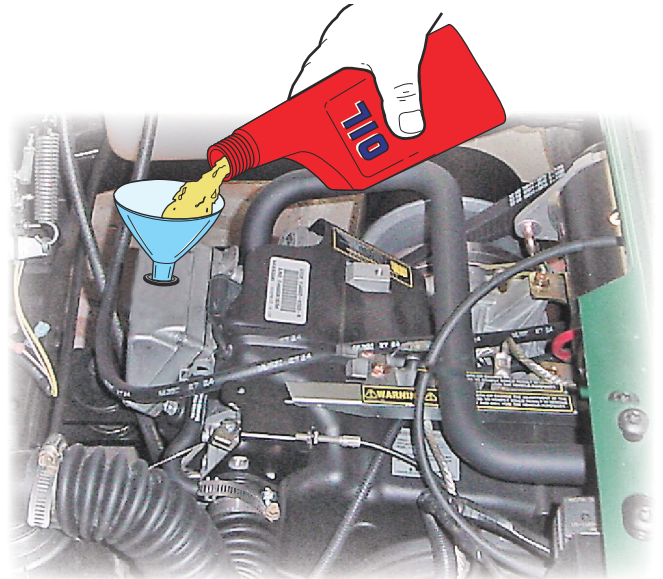

As a final check, check the oil level again with the vehicle on level ground. Like all liquids, oil increases in volume when warm. The full ‘H’ mark on the dipstick is calibrated for an engine at operating temperature. When the engine is cold, the oil will be below the full mark. The engine can be operated safely as long as the oil is within the safe operating range as indicated on the dipstick. **Do not operate vehicle if oil level is below the safe area indicated on the dipstick.**

MAINTENANCE

Read all of SAFETY and this section before attempting any procedure. Pay particular attention to Notices, Cautions, Warnings and Dangers.

STARTER/GENERATOR BELT TENSION

Tool List	Qty. Required	Tool List	Qty. Required
Belt Tension Gauge	1	Ratchet.....	1
Wrench, 3/4".....	1	Socket, 3/4".....	1
Wrench, 9/16".....	2		

The starter/generator belt tension should be checked after the first 15 - 20 hours and set to 75 - 80 lbs. (34 - 36 kg).

⚠ WARNING

Belt tension should never exceed 160 lbs (73 kg) at any point during belt installation process.

⚠ CAUTION

At the time of installation, the belt must not be rolled over the installed edges of the starter/generator or drive clutch pulleys. Excessive stretch in belt may cause cord failure.

NOTICE

A loose belt can cause audible vibration and squeal.

Tighten a **new** starter/generator belt to 110 - 130 lbs. (50 - 59 kg) tension when a gauge is applied half way between the two pulleys.

A **new** belt may be checked manually. A maximum deflection of 3/8" (10 mm) is acceptable. Tighten an **existing** belt to 75 - 80 lbs. (34 - 36 kg) tension using the same technique and inspect for cracking or wear. A maximum deflection of 1/2" (13 mm) is acceptable.

Adjusting the Belt

Loosen the starter/generator pivot bolt.

While holding the lower adjusting nut with a wrench, loosen the upper jam nut with another wrench. Move the lower nut up or down the adjustment bolt until proper belt tension is achieved. Hold the lower nut in place and tighten the upper jam nut against it.

Tighten the starter/generator pivot bolt.

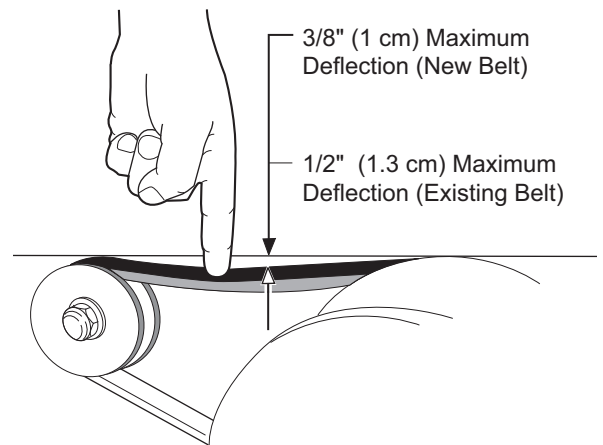

BATTERY CLEANING

⚠ CAUTION

To reduce the possibility of damage to vehicle or floor, neutralize acid before rinsing battery.

To reduce the possibility of damage to electrical components while cleaning, do not use a pressure washer.

Cleaning should take place per the Periodic Service Schedule on page 59

When cleaning the outside of the battery and terminals, first spray with a solution of sodium bicarbonate (baking soda) and water to neutralize any acid deposits before rinsing with clear water.

Read all of SAFETY and this section before attempting any procedure. Pay particular attention to Notices, Cautions, Warnings and Dangers.

Using a water hose without first neutralizing any acid, will move acid from the top of the battery to another area of the vehicle or storage facility where it will attack the metal structure or the concrete/asphalt floor. Additionally, a residue will be left on the battery which is conductive and will contribute to the discharge of the battery.

⚠ WARNING

To reduce the possibility of a battery explosion that could result in severe injury or death, do not use metallic spray wand to clean battery and keep all smoking materials, open flame or sparks away from the battery.

The correct cleaning technique is to spray the top and sides of the battery with a solution of sodium bicarbonate (baking soda) and water. This solution is best applied with a garden type sprayer equipped with a **non metallic spray wand or a plastic spray bottle**. The solution should consist of the amounts of sodium bicarbonate (baking soda) and clear water shown below. In addition to the battery, special attention should be paid to metal components adjacent to the battery which should also be sprayed with the sodium bicarbonate (baking soda) solution.

Allow solution to sit for at least three minutes; use a soft bristle brush or cloth to wipe the top of battery to remove any residue that could contribute to the self discharge of the battery. Rinse entire area with low pressure clear water. Do not use a pressure washer.

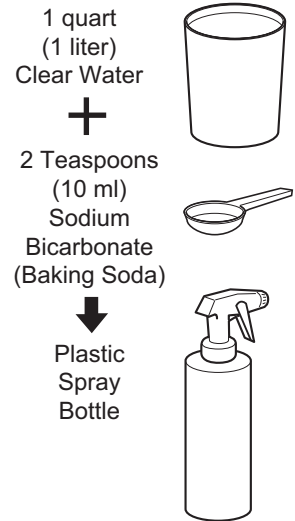

AIR INTAKE AND COOLING FINS

⚠ WARNING

To prevent possible burns, engine parts should be kept clean to reduce risk of overheating and ignition of accumulated debris. After every off road use, allow to cool and then check for a build up of dirt and debris in the air intake and cooling fins. Dirt and debris may clog the engine's air cooling system. Clean areas shown to prevent engine damage. Keep linkages, springs and controls clean. Keep area around muffler free of any combustible material.

At least once a year, (or more often under adverse conditions) the cooling system should be cleaned. Cleaning will assure an adequate supply of air to the cooling fins. Compressed air may be used for routine cooling system maintenance.

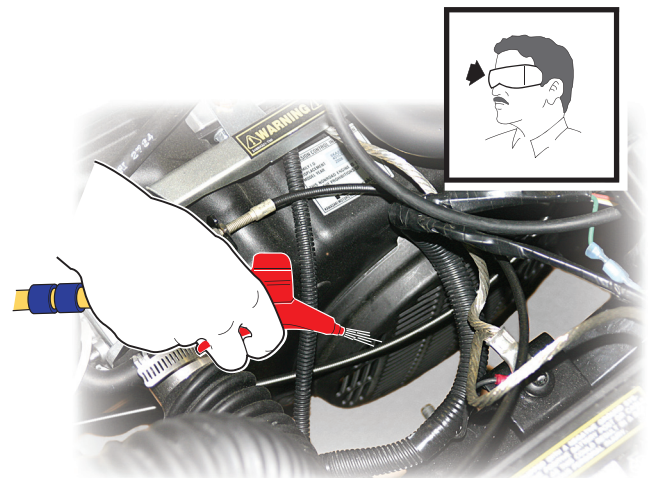

MAINTENANCE

Read all of SAFETY and this section before attempting any procedure. Pay particular attention to Notices, Cautions, Warnings and Dangers.

REAR AXLE

The rear axle is provided with a lubricant level check plug located on the driver side at the rear of the housing. Unless leakage of rear axle lubricant is evident, an annual lubricant check is sufficient.

Checking the Lubricant Level

Tool List	Qty. Required	Tool List	Qty. Required
Socket, 13 mm	1	Funnel	1
Ratchet	1		

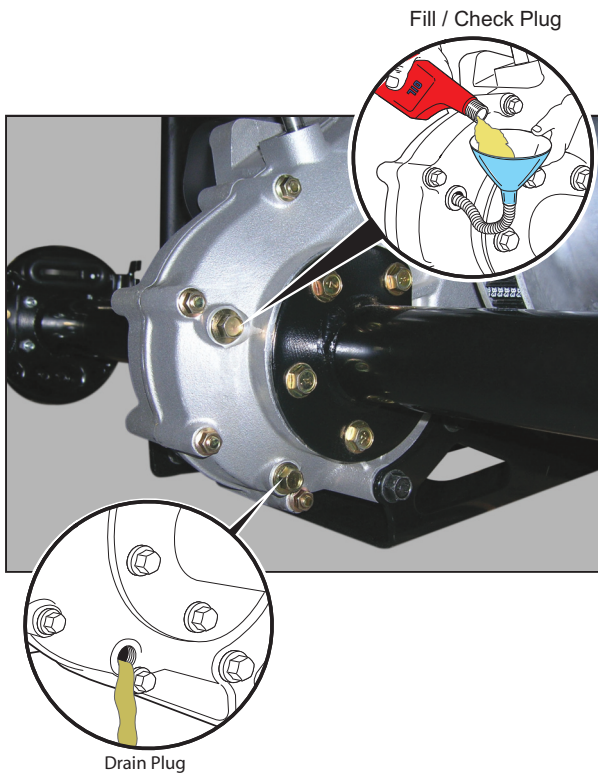

Clean area around the check and fill plugs. Remove check plug. The correct lubricant level is **just** below bottom of threaded hole. If lubricant is to be added, remove the fill plug and add lubricant using a funnel. Add lubricant slowly until lubricant starts to seep from the check plug hole. Install check plug and fill plug. In the event that lubricant is to be replaced, a drain plug is provided at the bottom of the differential housing.

AIR CLEANER INSPECTION AND REPLACEMENT

The air cleaner unit on the vehicle is a dry unit. **Do not** use oil on the filter element or any part of the unit. To aid installation and sealing, petroleum jelly may be applied to back side of cover tabs and each side of filter seal.

Cleaning the Air Filter Element



Do not use compressed air to clean the air filter. Compressed air will damage the filter which may result in damage to the engine.

Read all of SAFETY and this section before attempting any procedure. Pay particular attention to Notices, Cautions, Warnings and Dangers.

The air cleaner element is accessible by unsnapping the clips on the air canister and removing the cover and air filter element. Clean inside of cover, canister and dust collector. Install the element and cover the same way they were removed. Be sure the positioning arrow on cover is pointing upward and all clips are fastened securely.

If the element is in acceptable condition, loose dirt may be removed by tapping the filter lightly. Do not use oil on the filter element or any part of the unit.

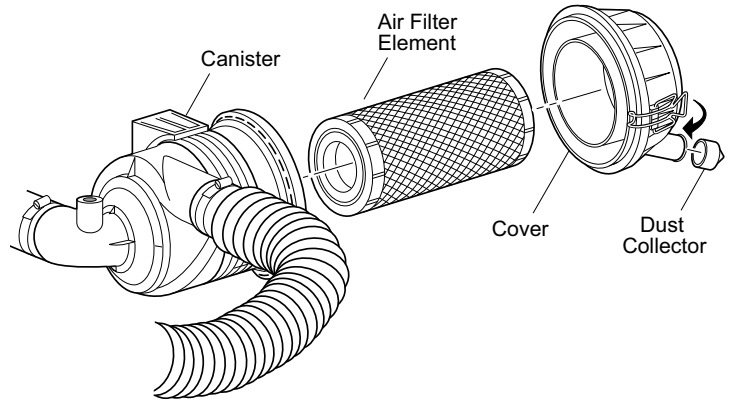

SPARK PLUG

Tool List	Qty. Required	Tool List	Qty. Required
Spark Plug Socket, 13/16"	1	Anti-Seize Compound	AR
Ratchet	1	Torque Wrench, ft. lbs.	1
Plug Gauge, Wire Type	1		

⚠ CAUTION

Do not to over-tighten the plug. Over-tightening can cause damage to the aluminum cylinder head threads.

Remove and inspect the spark plug at intervals indicated in the Periodic Service Schedule. Spark plug should be properly gapped. Tighten to 16 ft. lbs. (22 Nm) torque.

A fouled spark plug is indicated by a wet, black appearance. This could be caused by a dirty air filter element or other restrictions in the air intake system. Incorrectly adjusted valves, a spark plug wire in poor condition, or poor quality fuel could also contribute to the problem.

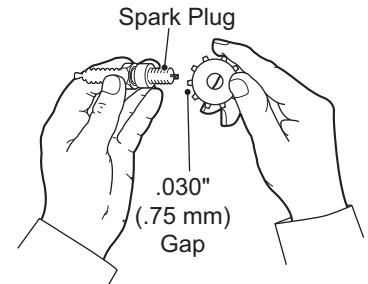

Gapping the spark plug

BRAKES

⚠ WARNING

To reduce the possibility of severe injury or death, always evaluate pedal travel before operating a vehicle to verify some braking function is present.

All driving brake tests must be done in a safe location with regard for the safety of all personnel.

NOTICE

A subtle loss of performance may take place over time; therefore, it is important to establish the standard with a new vehicle.

MAINTENANCE

Read all of SAFETY and this section before attempting any procedure. Pay particular attention to Notices, Cautions, Warnings and Dangers.

The Periodic Brake Performance test should be performed regularly as an evaluation of braking system performance. It is useful as a method of identifying subtle loss of performance over time.

Periodic Brake Test

WARNING

Unit should be empty, all drawers and cabinet doors secured, and passenger side countertop removed prior to performing the periodic brake test.

The purpose of this test is to compare the braking performance of the vehicle to the braking performance of new or 'known to be good' vehicles or to an established acceptable stopping distance. Actual stopping distances will be influenced by weather conditions, terrain, road surface condition, actual vehicle weight (accessories installed) and vehicle speed. No specific braking distance can be reliably specified. The test is conducted by latching the park brake to eliminate different pedal pressures and to include the affects of linkage mis-adjustment.

Establish the acceptable stopping distance by testing a new or 'known to be good' vehicle and recording the stopping location or stopping distance.

NOTICE

A subtle loss of brake performance may occur over time; therefore, it is important to establish the standard with a new vehicle.

Drive the vehicle at maximum speed on a flat, dry, clean, paved surface.

Quickly press the brake pedal to latch the parking brake at the line or marker in the test area; remove foot from pedal. The vehicle should stop aggressively. The wheel brakes may or may not lock.

Observe the vehicle stopping location or measure the vehicle stopping distance from the point at which the brakes were latched. The vehicle should stop within the 'acceptable stopping distance' range of stopping distances. If the vehicle requires more than 4 ft. (1.2 m) beyond the acceptable stopping distance, or pulls to one side, the vehicle has failed the test and should be tested again.

If the vehicle fails the second test, it should **immediately** be removed from service. The vehicle **must** be inspected by a qualified mechanic who should refer to the TROUBLESHOOTING section in the Technician's Repair and Service Manual.

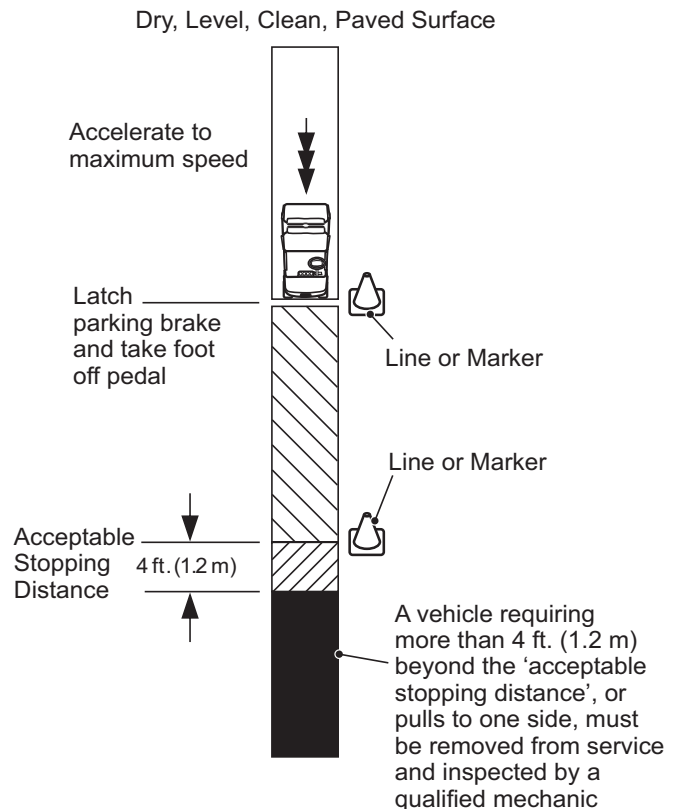

Read all of SAFETY and this section before attempting any procedure. Pay particular attention to Notices, Cautions, Warnings and Dangers.

LUBRICATION

⚠ CAUTION

Do not use more than three pumps of grease in any grease fitting at any one time. Excess grease may cause grease seals to fail or grease migration into areas that could damage components.

Putting more than three pumps of grease in a grease fitting could damage grease seals and cause premature bearing failure.

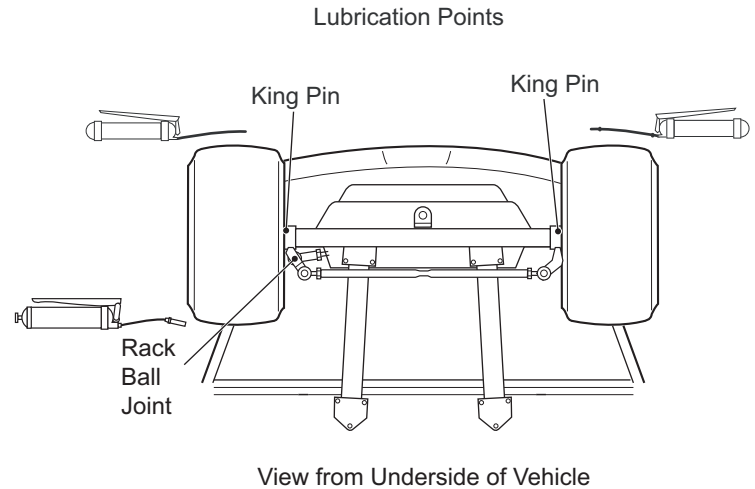

PROLONGED STORAGE

⚠ WARNING

To reduce the possibility of severe injury or death resulting from a possible explosion:

Do not handle fuel in an area that is not adequately ventilated. Do not smoke near the fuel tank or refuel near open flame or electrical items which could produce a spark.

Store vehicle in a clean, dry area. Do not store in same area as a stove, furnace, water heater, or other appliance that uses a pilot light or has a device that can create a spark.

When refueling, inspect the fuel cap for leaks or breaks that could result in fuel spillage.

Always wear safety glasses while refueling to prevent possible eye injury from gasoline or gasoline vapor.

Keep hands, clothing and jewelry away from moving parts. Use care not to contact hot objects. Raise the rear of the vehicle and support on jack stands before attempting to run the engine.

Preparing the engine for a prolonged storage period (30 days or more) requires a few simple steps to prevent a build up of varnish and gum in the carburetor and corrosion in the engine.

1. Turn the key switch to OFF position.
2. Perform all required routine maintenance per the Periodic Service Schedule.
3. Properly inflate tires to recommended pressure (psi) stated on sidewall of tires.
4. Place forward/reverse handle in NEUTRAL position.
5. Engage neutral lock.

MAINTENANCE

Read all of SAFETY and this section before attempting any procedure. Pay particular attention to Notices, Cautions, Warnings and Dangers.

6. Turn fuel shut-off valve to closed (OFF) position.
7. In a properly ventilated area, run engine until remaining fuel in carburetor and fuel lines is depleted and the engine stalls.
8. Return neutral lock to OPERATE position.
9. Loosen (do not remove) the carburetor drain screw. Allow any remaining fuel to drain into an approved container and pour the fuel collected into the vehicle fuel tank.
10. Add Sea Foam (4 oz. for a full tank of fuel) to stabilize fuel and install the tank cap securely.
11. Tighten carburetor drain screw.
12. Remove spark plug and pour approximately 1/2 oz. (15 ml) of SAE 10 - 30 weight oil or fogging oil into the cylinder.
13. Rotate the crankshaft by hand several times, then install the spark plug.
14. Do not engage the park brake, but secure the car from rolling.
15. Change oil while engine is still warm.
16. Clean body, chassis and engine of debris, mud, chaff or grass.

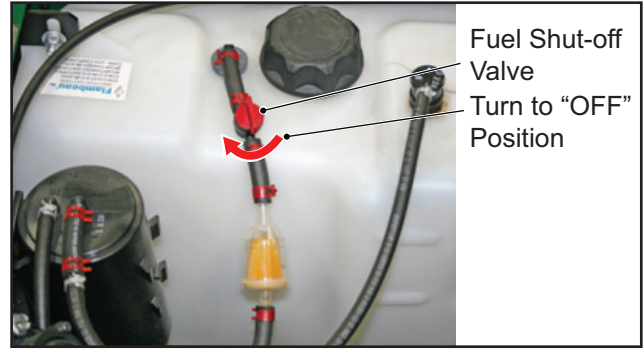

CAPACITIES AND REPLACEMENT PARTS







Fuel Tank Capacity (Early Production)	6.0 gal (22.7 liters) / 87 Octane Min
Fuel Tank Capacity (Late Production)	5.2 gal (19.8 liters) / 87 Octane Min
Engine Oil	1.4 US qt (1.3 liters)
Oil Filter	P/N 607454
Air Filter	P/N 28463G01
Spark Plug	NGK BPR2ES (P/N 607462) .028" - .031" (.7 mm - .8 mm) Gap
Starter/Generator Belt	P/N 26414G1
Clutch Belt	P/N 618630
Rear Axle Oil	51 oz (1.5 liters) / SAE 30
Fuse	15 amp (P/N 18392G1)
LED Bulb	(P/N 619101)
Headlight Bulb	(P/N 619100)
Turn Signal Bulb	(P/N 619102)
Taillight Bulb	#1157 (P/N 611242)
Friction Modifier (Rear Axle)	2 oz (60 mL) (P/N 625753)

Read all of SAFETY and this section before attempting any procedure. Pay particular attention to Notices, Cautions, Warnings and Dangers.

HARDWARE

Periodically, the vehicle should be inspected for loose fasteners. Fasteners should be tightened in accordance with the Torque Specifications table.

Generally, three grades of hardware are used in the vehicle. Grade 5 hardware can be identified by the three marks on the hexagonal head and grade 8 hardware is identified by 6 marks on the head. Unmarked hardware is Grade 2.

ALL TORQUE FIGURES ARE IN FT. LBS. (Nm)											
Unless otherwise noted in text, tighten all hardware in accordance with this chart.											
This chart specifies 'lubricated' torque figures. Fasteners that are plated or lubricated when installed are considered 'wet' and require approximately 80% of the torque required for 'dry' fasteners.											
BOLT SIZE		1/4"	5/16"	3/8"	7/16"	1/2"	9/16"	5/8"	3/4"	7/8"	1"
Grade 2 		4 (5)	8 (11)	15 (20)	24 (33)	35 (47)	55 (75)	75 (102)	130 (176)	125 (169)	190 (258)
Grade 5 		6 (8)	13 (18)	23 (31)	35 (47)	55 (75)	80 (108)	110 (149)	200 (271)	320 (434)	480 (651)
Grade 8 		6 (8)	18 (24)	35 (47)	55 (75)	80 (108)	110 (149)	170 (230)	280 (380)	460 (624)	680 (922)
BOLT SIZE		M4	M5	M6	M8	M10	M12	M14			
Class 5.8 (Grade 2) 		1 (2)	2 (3)	4 (6)	10 (14)	20 (27)	35 (47)	55 (76.4)			
Class 8.8 (Grade 5) 		2 (3)	4 (6)	7 (10)	18 (24)	35 (47)	61 (83)	97 (131)			
Class 10.9 (Grade 8) 		3 (4)	6 (8)	10 (14)	25 (34)	49 (66)	86 (117)	136 (184)			

MAINTENANCE

Read all of SAFETY and this section before attempting any procedure. Pay particular attention to Notices, Cautions, Warnings and Dangers.

Notes:

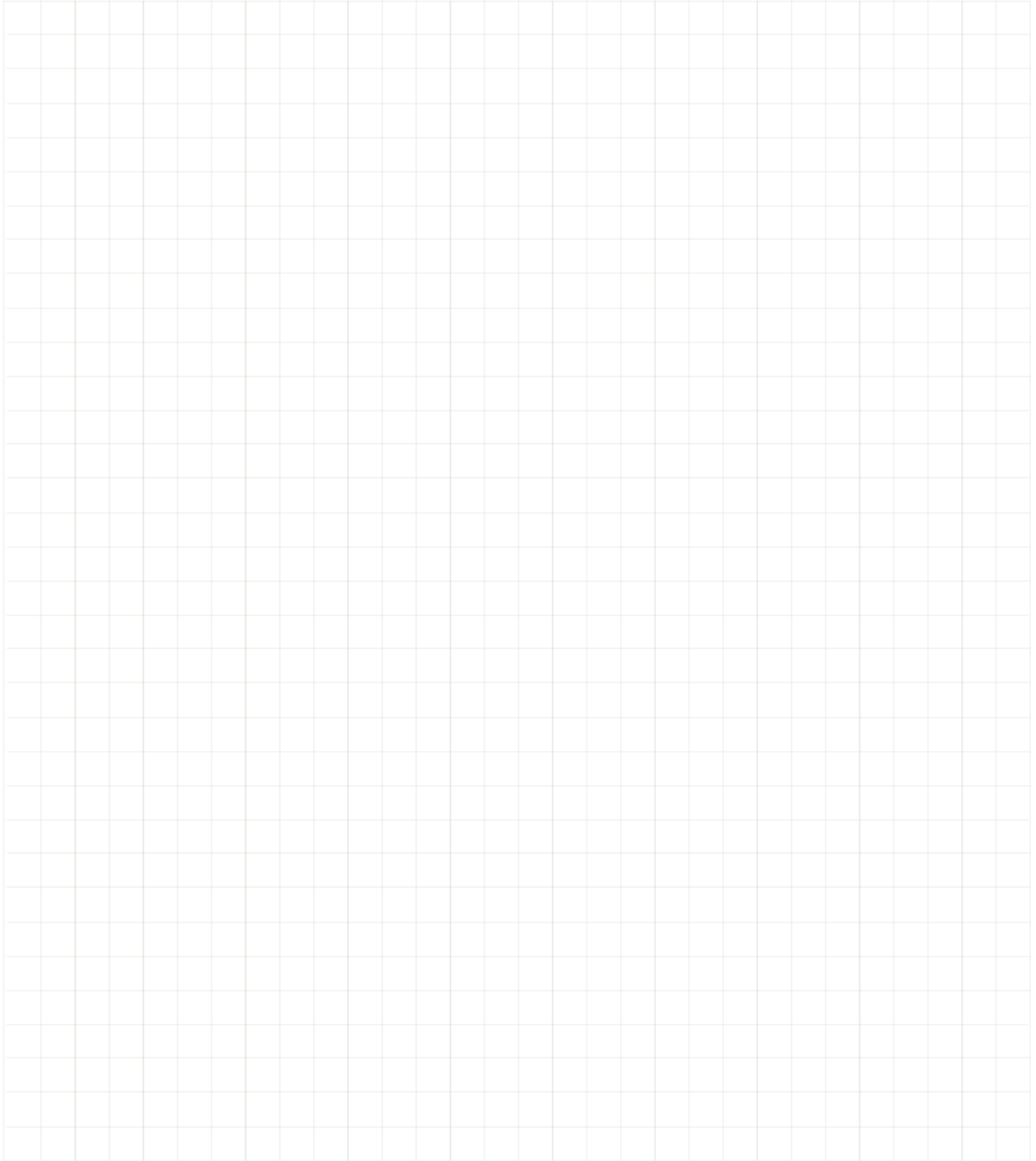
A large grid of graph paper for taking notes. The grid consists of 20 columns and 30 rows of small squares, providing a structured area for writing or drawing.

PERIODIC SERVICE SCHEDULE

Read all of SAFETY and this section before attempting any procedure. Pay particular attention to Notices, Cautions, Warnings and Dangers.

PERIODIC SERVICE SCHEDULE

PERIODIC SERVICE SCHEDULE

✓ Check ♦ Clean, Adjust, etc. ▲ Replace

To perform service that is listed in this schedule but not described in this manual, contact a local Service Representative or see the Repair and Service Manual for this vehicle.

NOTE: Some maintenance items must be serviced more frequently on vehicles used under severe driving conditions

DAILY

BEFORE USE:

- ✓ Check service brake general operation
- ✓ Check park brake operation - does it hold on a hill.
- ✓ Check warning device function in reverse
- ✓ Check tire pressure, condition of tires & rims.
- ✓ Check smooth operation of accelerator.
- ✓ Check for loose or missing hardware.
- ✓ Check Battery - state of charge, condition, loose terminals, corrosion, hold down & hardware
- ✓ Check overall vehicle condition

WEEKLY (includes items listed in previous table & the following)

TIRES	✓ Examine for cuts, excessive wear and pressure (See GENERAL SPECIFICATIONS)
WHEELS	✓ Check for bent rims, missing or loose lug nuts
COOLING FAN	✓ Check for build-up of foreign matter inside blower housing and fins, clean if required
ENGINE OIL	✓ Check and add if required - DO NOT OVERFILL
STARTER/GENERATOR BELT	✓ Check for tension, wear, cracks

MONTHLY - 20 HOURS (includes items listed in previous table & the following)

WIRING	✓ Check all wiring for loose connections and broken/missing insulation
ACCELERATOR	✓ Check for smooth movement - DO NOT LUBRICATE CABLE
SERVICE BRAKE (MECHANICAL BRAKES)	✓ Conduct brake performance test
PARK BRAKE	✓ Check brake performance and adjust if required
CHOKE CABLE	✓ Check for smooth movement and adjustment - DO NOT LUBRICATE CABLE
CARBURETOR LINKAGE	✓ Check attachment, adjust as required
DIRECTION SELECTOR	✓ Check attachment, adjust as required
ENGINE	✓ Check for unusual noise, vibration, acceleration, oil leaks
COOLING FAN	✓ Check for build-up of foreign matter inside blower housing and fins, clean if required
STEERING ASSEMBLY	✓ Check for abnormal play, tightness of all hardware
TIE ROD/LINKAGES	✓ Check for excessive play, bent components or loose connections
REAR AXLE	✓ Check for leakage, add SAE 30 oil as required

QUARTERLY - 60 HOURS (includes items listed in previous tables & the following)

FRONT AXLE	✓ Check for damage to axle and loose or missing hardware
FRONT SHOCK ABSORBERS	✓ Check for oil leakage and loose fasteners
FRONT SPRINGS	✓ Check for loose hardware, cracks at attachments
FRONT WHEEL ALIGNMENT	✓ Check for unusual tire wear, align if required

Periodic Service Schedule

PERIODIC SERVICE SCHEDULE

Read all of SAFETY and this section before attempting any procedure. Pay particular attention to Notices, Cautions, Warnings and Dangers.

PARK BRAKE	<ul style="list-style-type: none"> ✓ Check for bent/binding linkage rod ✓ Check for damage or wear to latch arm or catch bracket ◆ Lubricate as required, use light oil. DO NOT LUBRICATE CABLES OR BRAKE LATCH
REAR SHOCK ABSORBERS	✓ Check for oil leakage, loose mounting hardware
ENGINE ELECTRICAL SYSTEM	✓ Check coil/spark plug wires for cracks/loose connections
FUEL SYSTEM	<ul style="list-style-type: none"> ✓ Check for leaks at tank, cap, system lines, filters, pump, carburetor ✓ Check system lines for cracks/deterioration
THROTTLE/GOVERNOR LINKAGE	✓ Check operation and governed speed
HARDWARE AND FASTENERS	<ul style="list-style-type: none"> ✓ Check for loose or missing hardware and components ◆ Tighten or replace missing hardware
SEMI-ANNUAL - 125 HOURS (includes items listed in previous tables & the following)	
BATTERY	◆ Clean battery & terminals
DIRECTION SELECTOR	✓ Check for wear and smooth movement (lubricate shaft with light oil if required)
KING PINS	✓ Check for excessive play and tightness of retaining nuts
STEERING ASSEMBLY	✓ Check bellows and pinion seal for damage or grease leakage
RACK END BALL JOINT	◆ Lubricate, use wheel bearing grease
REAR AXLE	✓ Check for unusual noise and loose or missing mounting hardware
AIR FILTER ELEMENT	✓ Check filter element, clean/replace as required
OIL FILTER	▲ Replace (at oil change)
ENGINE OIL	▲ Replace with SAE 10W-30 or 10W-40 that meets or exceeds SF, SG, CC oil, DO NOT OVERFILL
DRIVE BELT	✓ Check for cracks, fraying and excessive wear
ANNUAL - 250-300 HOURS (includes items listed in previous tables & the following)	
FRONT WHEEL BEARINGS	✓ Check and adjust as required, see Technician's Repair and Service Manual
REAR AXLE	✓ Check lubricant, add lubricant as required
SERVICE BRAKES	<ul style="list-style-type: none"> ◆ Clean and adjust, see Technician's Repair and Service Manual ✓ Check brake shoe linings, see Technician's Repair and Service Manual ✓ Check level, add if required (DOT 3) and check for leakage
FUEL FILTER	▲ Replace
SPARK PLUG	▲ Replace, gap new plug
MUFFLER/EXHAUST	✓ Check mounting hardware; check for leaks at head and muffler gaskets
VALVES	✓ Check cold (intake/exhaust) per Technician's Repair and Service Manual
500 HOURS (includes items listed in previous tables & the following)	
CARBURETOR	◆ Clean
CYLINDER HEAD AND PISTON	<ul style="list-style-type: none"> ◆ Remove carbon from cylinder head and piston ✓ Check valve seats for carbon buildup and clean as required

Periodic Service Schedule (Continued)

Read all of SAFETY and this section before attempting any procedure. Pay particular attention to Notices, Cautions, Warnings and Dangers.

Notes:

A large grid area for taking notes, consisting of 25 columns and 30 rows of empty squares.

Read all of SAFETY and this section before attempting any procedure. Pay particular attention to Notices, Cautions, Warnings and Dangers.

APPENDIX A

DECLARATION OF CONFORMITY

APPENDIX A

Read all of SAFETY and this section before attempting any procedure. Pay particular attention to Notices, Cautions, Warnings and Dangers.

**DECLARATION OF CONFORMITY • ДЕКЛАРАЦИЯ ЗА СЪОТВЕТСТВИЕ • PROHLÁŠENÍ O SHODĚ •
 OVERENSSTEMMELSESERKLÆRING • CONFORMITEITSVERKLARING • VASTAVUSDEKLARATSIOON •
 VAATIMUSTENMUKAISUVAKUUTUS • DECLARATION DE CONFORMITE • KONFORMITÄT SERKLÄRUNG • ΔΗΛΩΣΗ
 ΣΥΜΜΟΡΦΩΣΗΣ • MEGFELELŐSÉGI NYILATKOZAT • DICHIARAZIONE DI CONFORMITÀ • ATBILSTĪBAS DEKLARĀCIJA •
 ΑΤΙΤΙΚΤΕΣ DEKLARACIJA • DIKJARAZZJONI TAL-KONFORMITÀ • DEKLARACJA ZGODNOŚCI • DECLARAÇÃO DE
 CONFORMIDADE • DECLARAȚIE DE CONFORMITATE • VYHLÁSENIE O ZHODE • IZJAVA O SKLADNOSTI • DECLARACIÓN DE
 CONFORMIDAD • DEKLARATION OM ÖVERENSSTÄMMELSE • SAMRÆMISYFIRLÝSING • KONFORMITETSERKLÆRING •
 符合性声明 • SAMRÆMISYFIRLÝSING • 適合宣言 • 적합성 선언서 • UYGUNLUK BEYANI • ДЕКЛАРАЦИЯ ПРО ВІДПОВІДНІСТЬ**

<p>Business name and full address of the manufacturer • Търговско име и пълен адрес на производителя • Obchodní jméno a plná adresa výrobce • Producentens firmanavn og fulde adresse • Bedrijfsnaam en volledig adres van de fabrikant • Toetja ärinimi ja täielik address • Valmistajan toimintini ja täydellinen osoite • Nom commercial et adresse complète du fabricant • Firmenname und vollständige Adresse des Herstellers • Επωνυμία και ταχυδρομική διεύθυνση κατασκευαστή • A gyártó üzleti neve és teljes címe • Ragione sociale e indirizzo completo del fabbricante • Uzņēmuma nosaukums un pilna ražotāja adrese • Verslo pavadinimas ir pilnas gamintojo adresas • Isem kummerčialni u indirizz shih tal-fabrikant • Nazwa firmy i pełny adres producenta • Nome da empresa e endereço completo do fabricante • Denumirea comercială și adresa completă a producătorului • Obchodný názov a úplná adresa výrobcu • Naziv podjetja in polni naslov proizvajalca • Nombre de la empresa y dirección completa del fabricante • Tillverkarens företagsnamn och kompletta adress • Fyrirtækisheiti og fullt heimilisfang framleiðanda • Firmanavn og full adresse for produsenten • 製造商の商号名称和完整地址 • Nafn fyrirtækis og fullt heimilisfang framleiðanda • 商号およびメーカーの正式住所 • 제조사의 상호명 및 주소 • Imalatçının ticari ünvanı ve açık adresi • Фірмова найменування і повна адреса виробника</p>	<p>E-Z-GO Division of Textron Inc. 1451 Marvin Griffin Road Augusta, GA 30906 USA</p>
<p>Product Code • Код на продукта • Kód výrobku • Produktkode • Productcode • Toote kood • Tuotekoodi • Code produit • Produktcode • Κωδικός προϊόντος • Termékkód • Codice prodotto • Produkta kods • Produktu kods • Kódici tal-Prodott • Kod produktu • Código do Produto • Cod produs • Kód výrobku • Oznaka proizvoda • Código de producto • Produktkod • Vörunúmer • Produktkode • 产品代码 • Framleiðslunúmer • 製品コード • 제품 코드 • Ürün Kodu • Код виробу</p>	<p>617791, 618841, 618843, 618844, 618846, 618847, 618855, 618850, 618860, 630111, 633911 and 639075 when fitted with CE Kit 614168. 625111, 625113 and 625115 when fitted with CE Kit 634296.</p>
<p>Machine Name • Наименование на машината • Název stroje • Maskinnavn • Machinaam • Masina nimi • Laitteen nimi • Nom de la machine • Maschinenbezeichnung • Ονομασία μηχανήματος • Gérnév • Denominazione della macchina • Iekártas nosaukums • Mašinos pavadinimas • Isem tal-Magna • Nazwa urządzenia • Nome da Máquina • Numele echipamentului • Název stroja • Naziv stroja • Nombre de la máquina • Maskinens namn • Helti tækis • Maskinnavn • 机器名称 • Nafn vélar • 機械名 • 기기 명칭 Makine Adı • Назва машини</p>	<p>E-Z-GO terrain, Cushman Hauler, Bad Boy Buggies Utility and Refresher Utility vehicles (gasoline models), E-Z-GO, Cushman and Bad Boy Buggies brands.</p>
<p>Designation • Предназначение • Označení • Betegnelse • Benaming • Nimetus • Tyypimerkintä • Pažymėjimas • Bezeichnung • Χαρακτηρισμός • Megnevezés • Funzione • Apzīmējums • Lithuanian • Denominazzjoni • Oznaczenie • Designação • Specificație • Označenje • Namen stroja • Descripción • Beteckning • Merking • Konstruksjon • 名称 • Útnefning • 用途 • 지용 • Тапим • Позначення</p>	<p>Utility and FS2 and FS4 Refreshment vehicles E-Z-GO and Cushman brand</p>
<p>Serial Number • Серийн номер • Sériové číslo • Seriennummer • Seriennummer • Seerianumber • Valmistusnumero • Numéro de série • Seriennummer • Σειριακός αριθμός • Sorozatszám • Numero di serie • Sérijas numurs • Serijos numeris • Numru Serjali • Numer seryjny • Número de Série • Număr de serie • Sériové číslo • Serijska številka • Número de serie • Seriennummer • Raðnúmer • Seriennummer • 序列号 • Raðnúmer • シリアル番号 • 일련 번호 • Seri Numarasi • Серийний номер</p>	<p>2839700 - 3400000</p>
<p>Conforms to Directives • В съответствие с директивите • Splūuje podminky smárnice • Er i overensstemmelse med direktiver • Voldoet aan de richtlijnen • Vastab direktiividele • Direktiiven mukainen • Conforme aux directives • Entspricht Richtlinien • Ακολουθείτε πιστά τις Οδηγίες • Megfelel az irányelveknek • Conforme alle Direttive • Albiist direktivām • Atitinka direktivų reikalavimus • Valutazzjoni tal-Konformità • Dyrektywy związane • Cumpra as Directivas • Respectă Directivele • Je v súlade so smernicami • Skladnost z direktivami • Cumple con las Directivas • Uppfylljer direktiv • Samræmist tilskipunum • I samsvar med direktiv • 符合指令 • Samræmi við reglugerðir • 適合指令 • 규정 준수 • 符合 Yönergelere Uymaktadır • Відповідає директиви</p>	<p>2006/42/EC 2004/108/EC</p>
<p>Conformity Assessment • Оценка за съответствие • Hodnocení plnění podmínek • Overensstemmelsesvurdering • Conformiteitsbeoordeling • Vastavushindamine • Vaatimustenmukaisuuden arviointi • Evaluation de conformité • Konformitätsbeurteilung • Διπίπωση Συμμόρφωσης • Megfelelőség-értékelés • Valutazione della conformità • Atbilstības novērtējums • Atitikties įvertinimas • Livell tal-Qawwa tal-Fross Imkejjel • Ocena zgodności • Avaliação de Conformidade • Evaluarea conformității • Vyhodnotenie zhodnosti • Ocena skladnosti • Evaluación de conformidad • Bedømming av overensstemmelse • Samræmismat • Konformitetsvurdering • 符合性评估 • Samræmismat • 適合性評価 • 적합성 평가 • Uygunluk Değerlendirilmesi • Оцінка відповідності</p>	<p>2006/42/EC Annex II</p>
<p>Harmonised standards used • Използвани хармонизирани стандарти • Použité harmonizované normy • Brugte harmoniserede standarder • Gebruikte geharmoniseerde standaards • Kasutatud ühtlustatud standardid • Käytetyt yhdenmukaistetut standardit • Normes harmonisées utilisées • Angewandte harmonisierte Normen • Εμπροσθενά πρότυπα που χρησιμοποιήθηκαν • Harmonizált szabványok • Standard armonizzati applicati • Izmantotie saskaņotie standarti • Panaudoti suderinti standartai • Standards armonizzati usati • Normy spójne powiązane • Normas harmonizadas usadas • Standardele armonizate utilizate • Použité harmonizované normy • Uporabljene usklajeni standardi • Estándares armonizados utilizados • Harmoniserade standarder som används • 所采用的协调标准 • Samstiltir staðlar notaðir • 整合規格 • 적용되는 조항 표준 • Kullannilan uyumlu standartlar • Використані гармонізовані стандарти</p>	<p>EN 61000-6-2 :2005 EN 61000-6-4: 2007 EN ISO 5349: 2001 EN ISO 11202: 2010</p>
<p>Technical standards and specifications used • Използвани технически стандарти и спецификации • Použité technické normy a specifikace • Brugte tekniske standarder og specifikationer • Gebruikte technische standaards en specificaties • Kasutatud tehnilised standardid ja spetsifikatsioonid • Käytetyt tekniset standardit ja eritelmat • Specifications et normes techniques utilisées • Angewandte technische Normen und Spezifikationen • Τεχνικά πρότυπα και προδιαγραφές που χρησιμοποιήθηκαν • Műszaki szabványok és specifikációk • Standard tecnici e specifiche applicati • Izmantotie tehniskie standarti un specifikaācijas • Panaudoti techniniai standartai ir techninė informacija • Standards u specifikkazjonijet teknici usati • Normy i specyfikacje techniczne powiązane • Normas técnicas e especificações usadas • Standardele tehnice și specificațiile utilizate • Použité technické normy a specifikácie • Uporabljene tehnični standardi in specifikacije • Estándares y especificaciones técnicas utilizadas • Tekniska standarder och specifikationer som används • Samræmdir staðlar sem notaðir eru • Benyttede harmoniserete standarder • 所采用的技术标准规范 • Tæknistaðlar og -kröfur notaðar • 技術規格および仕様書 • 적용되는 기술 표준 및 규격 • Kullannilan teknik standartlar ve sarfnameler •</p>	<p>ISO 2631-1: 1997</p>
<p>The place and date of the declaration • Место и дата на декларацията • Misto a datum prohlášení • Sted og dato for erklæringen • Plaats en datum van de verklaring • Deklaratsiooni väljastamise koht ja kuupäev • Vakuutuksen paikka ja päivämäärä • Lieu et date de la déclaration • Ort und Datum der Erklärung • Τόπος και ημερομηνία δήλωσης • A nyilatkozat kelte (hely és idő) • Luogo e data della dichiarazione • Deklarācijas vieta un datums • Deklaracijos vieta ir data • Il-post u d-data tad-dikjarazzjoni • Miejsce i data wystawienia deklaracji • Local e data da declaração • Locul și data declarajiei • Miesto a dátum vyhlásenia • Kraj in datum izjave • Lugar y fecha de la declaración • Plats och datum för deklarationen • Tæknistaðlar og tæknilysingar sem notaðar eru • Benyttede tekniske standarder og specifikasjoner • Staður og dagsetning yfirlýsingar • Sted og dato for erklæringen • 声明的地点与日期 • Staður og dagsetning yfirlýsingarinnar • 宣言場所および日付 • 선언 장소 및 일자 • Beyan yerli ve tarihli • Micçe i data ukladennia deklaracji</p>	<p>E-Z-GO Division of Textron Inc. 1451 Marvin Griffin Road Augusta, GA 30906 USA</p>

Read all of SAFETY and this section before attempting any procedure. Pay particular attention to Notices, Cautions, Warnings and Danqers.

Signature of the person empowered to draw up the declaration on behalf of the manufacturer, holds the technical documentation and is authorised to compile the technical file, and who is established in the Community.

Подпис на човека, упълномощен да състави декларацията от името на производителя, който поддържа техническата документация и е регистриран да изготви техническия файл и е регистриран в общността

Podpis osoby oprávněné sestavit prohlášení jménem výrobce, držitel technickou dokumentaci a osoby oprávněné sestavit technické soubory a založené v rámci Evropského společenství.

Underskrift af personen, der har fuldmagt til at udarbejde erklæringen på vegne af producenten, der er indehaver af dokumentationen og er bemyndiget til at udarbejde den tekniske journal, og som er baseret i nærområdet.

Handtekening van de persoon die bevoegd is de verklaring namens de fabrikant te tekenen, de technische documentatie bewaart en bevoegd is om het technische bestand samen te stellen, en die is gevestigd in het Woongebied.

Ühenduse registreerise kantud isiku allkirj, kes on volitatud tootja nimel deklaratsiooni koostama, kes omab tehnilist dokumentatsiooni ja kellel on õigus koostada tehniline toimik.

Sen henkilöllä allekirjoitus, jolla on valmistajan valtuutus vakuutuksen laadintaan, jolla on hallussaan tekniset asiakirjat, joka on valtuutettu laatimaan tekniset asiakirjat ja joka on sijoittautunut yhteisöön.

Signature de la personne habilitée à rédiger la déclaration au nom du fabricant, à détenir la documentation technique, à compiler les fichiers techniques et qui est implantée dans la Communauté.

Unterschrift der Person, die berechtigt ist, die Erklärung im Namen des Herstellers abzugeben, die die technischen Unterlagen aufbewahrt und berechtigt ist, die technischen Unterlagen zusammenzustellen, und die in der Gemeinschaft niedergelassen ist.

Υπογραφή ατόμου εξουσιοδοτημένου για την σύνταξη της δήλωσης εκ μέρους του κατασκευαστή, ο οποίος κατέχει την τεχνική έκθεση και έχει την εξουσιοδότηση να ταξινομήσει τον τεχνικό φάκελο και ο οποίος είναι διαρισμένος στην Κοινότητα.

A gyártó nevében meghatalmazott személy, akinek jogában áll módosítani a nyilatkozatot, a műszaki dokumentációt érzi, engedélyvel rendelkezik a műszaki fájel összeállításához, és aki a közösségben letelepedett személy.

Firma della persona autorizzata a redigere la dichiarazione a nome del fabbricante, in possesso della documentazione tecnica ed autorizzata a costituire il fascicolo tecnico, che deve essere stabilita nella Comunità.

Tās personas paraksts, kura ir pilnvarota deklarācijas sastādīšanai ražotāja vārdā, kurai ir tehniskā dokumentācija, kura ir pilnvarota sagatavot tehnisko reģistru un kura ir apstiprināta Kopienā.

Asmuo, kuris yra gana žinomas, kuriam gamintojas suteikė įgaliojimus sudaryti šią deklaraciją, ir kuris ją pasirašė, turi visą techninę informaciją ir yra įgaliotas sudaryti techninės informacijos dokumentą.

Il-firma tal-persuna awtorizzata li tfassal id-dikjarazzjoni f'isem il-fabbrikant, għandha d-dokumentazzjoni teknika u hija awtorizzata li tikkompila l-fajel tekniku u li hija stabbilita fil-Komunita.

Podpis osoby upowaznionej do sporządzenia deklaracji w imieniu producenta, przechowującej dokumentację techniczną, upowaznioną do stworzenia dokumentacji technicznej oraz wyznaczonyj ds. wspólnotowych.

Assinatura da pessoa com poderes para emitir a declaração em nome do fabricante, que possui a documentação técnica, que está autorizada a compilar o processo técnico e que está estabelecida na Comunidade.

Semnătura persoanei împuternicite să elaboreze declarația în numele producătorului, care deține documentația tehnică, este autorizată să compileze dosarul tehnic și este stabilită în Comunitate.

Podpis osoby poverenej vystavenim vyhlásenia v mene výrobcu, ktorá má technickú dokumentáciu a je oprávnená spracovať technické podklady a ktorá je umiestnená v Spoločenstve.

Podpis osebe, pooblaščene za izdelavo izjave v imenu proizvajalca, ki ima tehnično dokumentacijo in lahko sestavlja spis tehnične dokumentacije, ter ima sedež v Skupnosti.

Firma de la persona responsable de la declaración en nombre del fabricante, que posee la documentación técnica y está autorizada para recopilar el archivo técnico y que está establecido en la Comunidad.

Undertecknas av den som bemyndigad att upprätta deklarationen å tillverkarens vägnar, innehar den tekniska dokumentationen och är bemyndigad att sammanställa den tekniska informationen och som är etablerad i gemenskapen.

Undirskrift aðilans sem hefur umboð til að gera yfirlýsinguna fyrir hönd framleiðandans, hefur undir höndum tæknigögnin og hefur leyfi til að taka saman tækniskýrsluna, og er viðurkenndur innan evrópska efnahagssvæðisins.

Signaturen til personen som har fullmakt til å utferdige erklæringen på vegne av produsenten, er i besittelse av den tekniske dokumentasjonen, har autorisasjon til å utarbejde den tekniske filen og som har tilhold i EU.

獲得授權代表製造商起草聲明者的簽名，此人保留技術文檔并獲授權編譯技術文件，且是社區中獲得認可者。

Undirskrift starfsmanns sem hefur heimild til að rita yfirlýsinguna fyrir hendi framleiðandans, hefur umsjón með tæknigögnum og hefur heimild til að setja saman tæknilega skýrslu og sem er tengdur inni í samfélagið.

メーカーを代表して宣言書を起草し、技術文書を保有し技術ファイルを編集する権限を有し、地域において確固たる地位を築いている人物の署名。

2006/42/EC Annex II 1A: 2
 Tim Lansdell
 Technical Director
 17th March 2014
 Ransomes Jacobsen Limited
 West Road, Ransomes Europark,
 Ipswich, England, IP3 9TT



2006/42/EC Annex II 1A: 10
 Christopher W Spencer
 Vice President of Engineering
 E-Z-GO Division of Textron Inc.
 1451 Marvin Griffin Road
 Augusta, GA 30906 USA
 17th March 2014
 Signator

Certificate Number • Номер на сертификат • Číslo osvědčení • Certifikatnummer • Certificaatnummer • Sertifikaadi number • Hyväksyntänumero • Numéro de certificat • Bescheinigungsnummer • Αριθμός Πιστοποιητικού • Hitelesítési szám • Numero del certificato • Serifikata numers • Serifikato numeris • Numru tač-Certifikat • Numer certifikatu • Número do Certificado • Număr certificat • Číslo osvedčenia • Številka certifikata • Número de certificado • Certifikatsnummer • Númer skirteinis • Serifikatnummer • 证书编号 • Skirteinisnúmer • 認證番号 • 인증 번호 • Serifika Numarasi • Номер сертификата

E0000401

- GB**
United Kingdom
 - BE**
Belgium
 - BG**
Bulgaria
 - CH**
Switzerland
 - CN**
China
 - CY**
Cyprus
 - CZ**
Czech Republic
 - DE**
Germany
 - DK**
Denmark
 - EE**
Estonia
 - ES**
Spain
 - FI**
Finland
 - FR**
France
 - GR**
Greece
 - HU**
Hungary
 - IS**
Iceland
 - IT**
Italy
-
- JP**
Japan
 - KR**
Korea
 - LI**
Liechtenstein
 - LT**
Lithuania
 - LV**
Latvia
 - MT**
Malta
 - NL**
Netherlands
 - NO**
Norway
 - PL**
Poland
 - PT**
Portugal
 - RO**
Romania
 - RU**
Russia
 - SE**
Sweden
 - SI**
Slovenia
 - SK**
Slovakia
 - TR**
Turkey
 - UA**
Ukrain

APPENDIX A

Read all of SAFETY and this section before attempting any procedure. Pay particular attention to Notices, Cautions, Warnings and Dangers.

Notes:

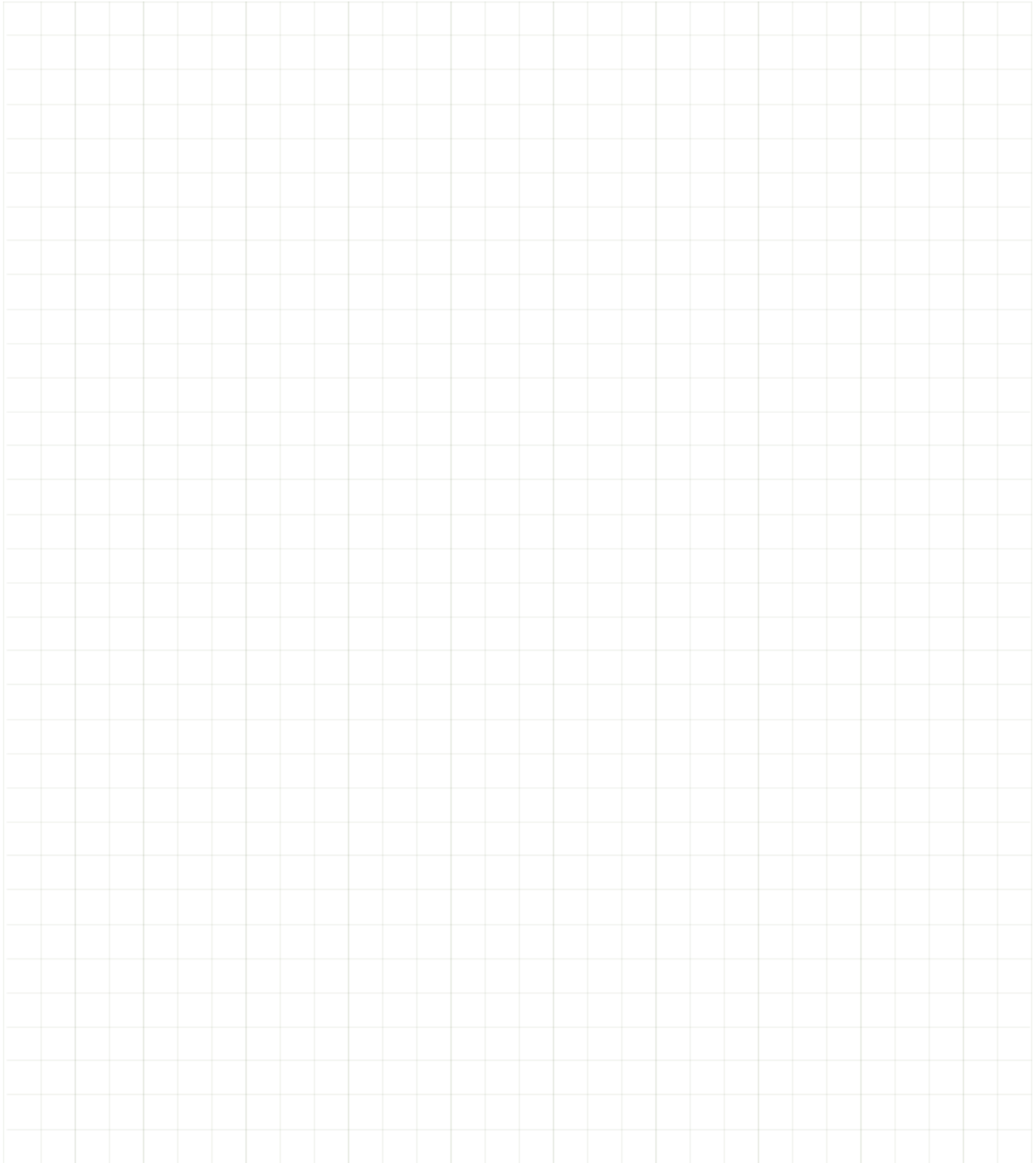
A large grid of graph paper for taking notes, consisting of 20 columns and 30 rows of small squares.

NOTICE

Read the following warnings before operating vehicle:

WARNING

To prevent personal injury or death, observe the following:

When vehicle is to be left unattended, engage park brake, move direction selector to neutral, turn key to OFF position and remove from key switch.

Drive vehicle only as fast as terrain and safety considerations allow. Consider environmental factors which effect the terrain and the ability to control the vehicle.

Avoid driving fast down hill. Sudden stops or change of direction may result in loss of control. Use service brake to control speed when traveling down an incline.

Use extra care and reduced speed when driving on poor surfaces, such as loose dirt, wet grass, gravel, etc.

All travel should be directly up or down hills; use extra care if ever forced to drive across an incline.

Stay in designated areas and avoid steep slopes. Activate the park brake when the vehicle is parked.

Keep feet, legs, hands and arms inside vehicle at all times.

Avoid extremely rough terrain.

Check area behind the vehicle before operating in reverse.

Make sure direction selector is in desired position before starting the vehicle.

Slow down before and during turns. All turns should be executed at reduced speed.

Always bring vehicle to a complete stop before shifting direction selector.

See GENERAL SPECIFICATIONS for vehicle load and seating capacity.

NOTICE

Read the following information and warnings before operating vehicle:

In any product, components will eventually fail to perform properly as the result of normal use, age, wear or abuse.

It is virtually impossible to anticipate all possible component failures or the manner in which they may fail.

A vehicle requiring repair indicates that it is no longer functioning as designed and therefore should be considered potentially hazardous.

Use extreme care when working on vehicle. When diagnosing, removing or replacing any components that are not operating properly, take time to consider the safety of yourself and others around you should the component move unexpectedly.

Some components are heavy, spring loaded, highly corrosive, explosive, may produce high amperage or reach high temperatures. Battery acid and hydrogen gas could result in serious bodily injury to the technician/mechanic and bystanders if not treated with utmost caution. Be careful not to place hands, face, feet or body in a location that could expose them to injury should an unexpected situation occur.

Always use the appropriate tools listed in the tool list and wear approved safety equipment.

WARNING

Before working on vehicle, remove all jewelry (rings, watches, necklaces, etc.).

Be sure no loose clothing or hair can contact moving parts.

Use care not to touch hot objects.

Raise rear of vehicle and support on jack stands before running or adjusting power-train.

Wear eye protection when working on or around the vehicle. In particular, use care when working around batteries, using solvents, or compressed air.

Hydrogen gas forms when charging batteries. Do not charge batteries without adequate ventilation.

Do no permit open flame or smokers in an area being used for charging batteries. A concentration of 4% hydrogen gas or more is explosive.



CUSHMAN™

E-Z-GO Division of Textron Inc.

1451 Marvin Griffin Road, Augusta, Georgia 30906-3852 USA

CONTACT US:

North America:

**Technical Assistance & Warranty
Service Parts**

Phone: 1-800-774-3946, FAX: 1-800-448-8124

Phone: 1-888-GETEZGO (1-888-438-3946), FAX: 1-800-752-6175

International:

Phone: 001-706-798-4311, FAX: 001-706-771-4609

Service Parts Manuals, as well as Repair and Service Manuals
are available from a local Distributor, an authorized Branch,
Genuine E-Z-GO Parts & Accessories Department or at www.shopezgo.com.

Copyrighted Material

This manual may not be reproduced in whole
or in part without the express permission of
E-Z-GO Division of Textron Inc.,
Technical Communications Department